



- ★ Green Device Available
- ★ Super Low Gate Charge
- ★ Excellent CdV/dt effect decline
- ★ Advanced high cell density Trench technology

### CST2318 Product Summary



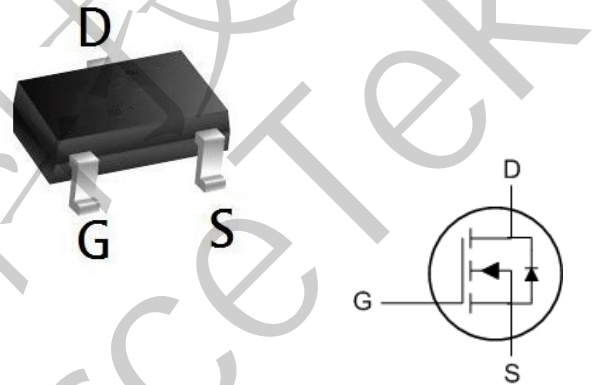
BVDSS	RDSON	ID
40V	30mΩ	5 A

### CST2318 Description

The CST2318 is the high cell density trenched N-ch MOSFETs, which provide excellent RDSON and gate charge for most of the synchronous buck converter applications.

The CST2318 meet the RoHS and Green Product requirement, 100% EAS guaranteed with full function reliability approved.

### CST2318 SOT 23 Pin Configurations



### CST2318 Absolute Maximum Ratings ( $T_A=25^{\circ}\text{C}$ unless otherwise specified)

Symbol	Parameter	Max.	Units	
$V_{DSS}$	Drain-Source Voltage	40	V	
$V_{GSS}$	Gate-Source Voltage	$\pm 20$	V	
$I_D$	Continuous Drain Current	$T_A = 25^{\circ}\text{C}$	5	A
		$T_A = 100^{\circ}\text{C}$	3	A
$I_{DM}$	Pulsed Drain Current <sup>note1</sup>	20	A	
$P_D$	Power Dissipation	$T_A = 25^{\circ}\text{C}$	1.6	W
$R_{\theta JA}$	Thermal Resistance, Junction to Ambient	78	$^{\circ}\text{C}/\text{W}$	
$T_J, T_{STG}$	Operating and Storage Temperature Range	-55 to +150	$^{\circ}\text{C}$	



### CST2318 Electrical Characteristics ( $T_J=25^\circ\text{C}$ unless otherwise specified)

Symbol	Parameter	Test Condition	Min.	Typ.	Max.	Units
<b>Off Characteristic</b>						
$V_{(BR)DSS}$	Drain-Source Breakdown Voltage	$V_{GS}=0V, I_D=250\mu A$	40	-	-	V
$I_{DSS}$	Zero Gate Voltage Drain Current	$V_{DS}=40V, V_{GS}=0V,$	-	-	1.0	$\mu A$
$I_{GSS}$	Gate to Body Leakage Current	$V_{DS}=0V, V_{GS}=\pm 20V$	-	-	$\pm 100$	nA
<b>On Characteristics</b>						
$V_{GS(th)}$	Gate Threshold Voltage	$V_{DS}=V_{GS}, I_D=250\mu A$	1.0	1.5	2.2	V
$R_{DS(on)}$	Static Drain-Source on-Resistance <small>note3</small>	$V_{GS}=10V, I_D=4A$	-	30	40	m $\Omega$
		$V_{GS}=4.5V, I_D=3A$	-	40	60	
<b>Dynamic Characteristics</b>						
$C_{iss}$	Input Capacitance	$V_{DS}=20V, V_{GS}=0V,$ $f=1.0MHz$	-	435	-	pF
$C_{oss}$	Output Capacitance		-	58	-	pF
$C_{rss}$	Reverse Transfer Capacitance		-	35	-	pF
$Q_g$	Total Gate Charge	$V_{DS}=20V, I_D=3A,$ $V_{GS}=10V$	-	11	-	nC
$Q_{gs}$	Gate-Source Charge		-	2	-	nC
$Q_{gd}$	Gate-Drain("Miller") Charge		-	2.5	-	nC
<b>Switching Characteristics</b>						
$t_{d(on)}$	Turn-on Delay Time	$V_{DD}=20V, I_D=4A,$ $R_L=1\Omega, R_{GEN}=3\Omega,$ $V_{GS}=10V$	-	10	-	ns
$t_r$	Turn-on Rise Time		-	8	-	ns
$t_{d(off)}$	Turn-off Delay Time		-	29	-	ns
$t_f$	Turn-off Fall Time		-	12	-	ns
<b>Drain-Source Diode Characteristics and Maximum Ratings</b>						
$I_S$	Maximum Continuous Drain to Source Diode Forward Current		-	-	5	A
$I_{SM}$	Maximum Pulsed Drain to Source Diode Forward Current		-	-	20	A
$V_{SD}$	Drain to Source Diode Forward Voltage	$V_{GS}=0V, I_S=5A$	-	-	1.2	V
$t_{rr}$	Body Diode Reverse Recovery Time	$T_J=25^\circ\text{C},$ $I_F=5A, di/dt=100A/\mu s$	-	20	-	ns
$Q_{rr}$	Body Diode Reverse Recovery Charge		-	11	-	nC

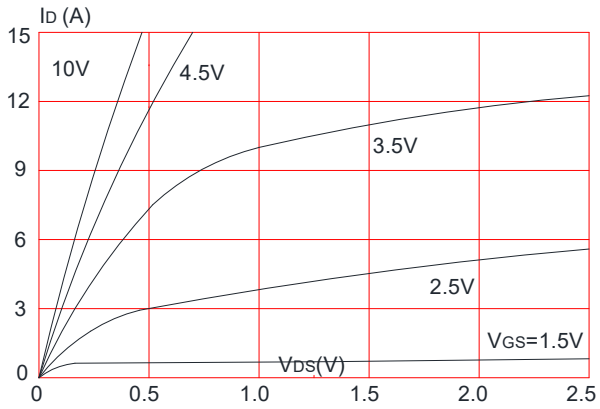
Notes: 1. Repetitive Rating: Pulse Width Limited by Maximum Junction Temperature

2. Pulse Test: Pulse Width $\leq 300\mu s$ , Duty Cycle $\leq 0.5\%$

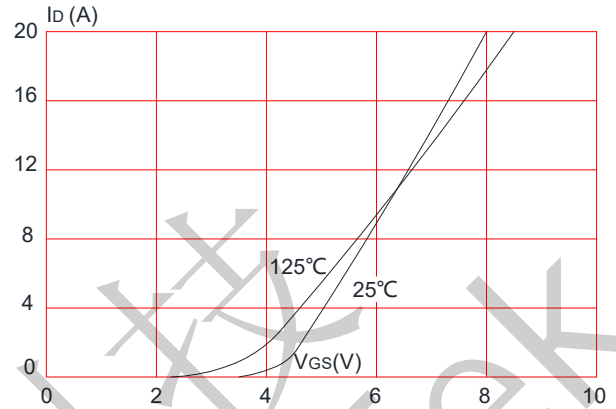


## CST2318 Typical Performance Characteristics

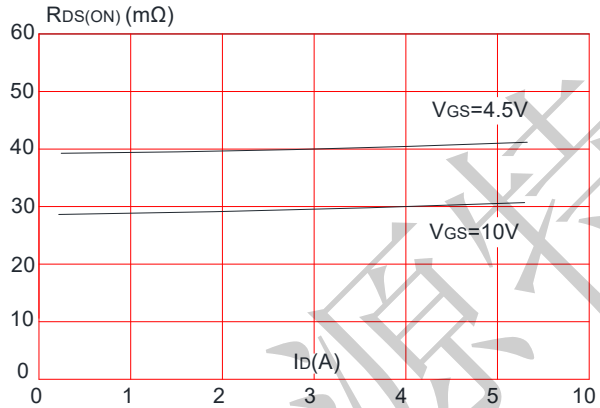
**Figure 1: Output Characteristics**



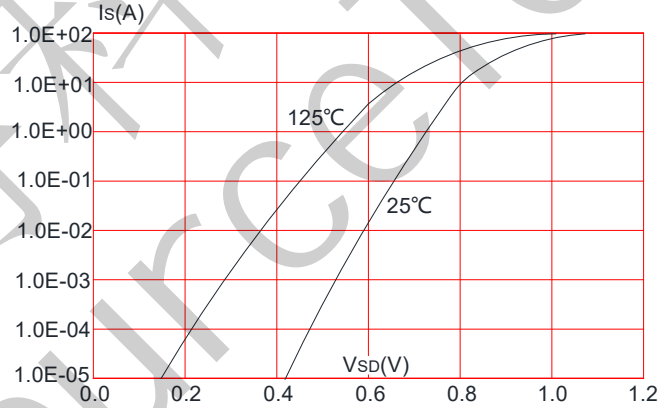
**Figure 2: Typical Transfer Characteristics**



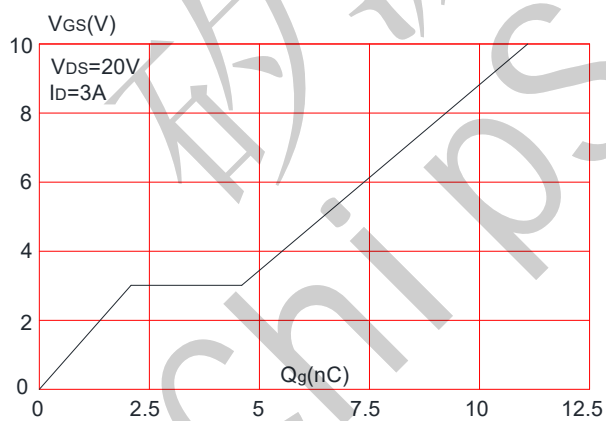
**Figure 3: On-resistance vs. Drain Current**



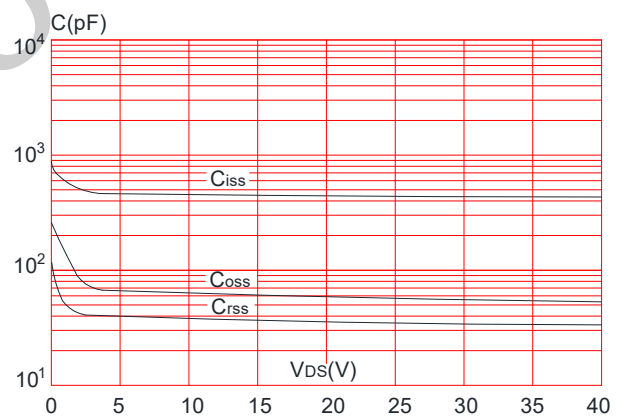
**Figure 4: Body Diode Characteristics**



**Figure 5: Gate Charge Characteristics**

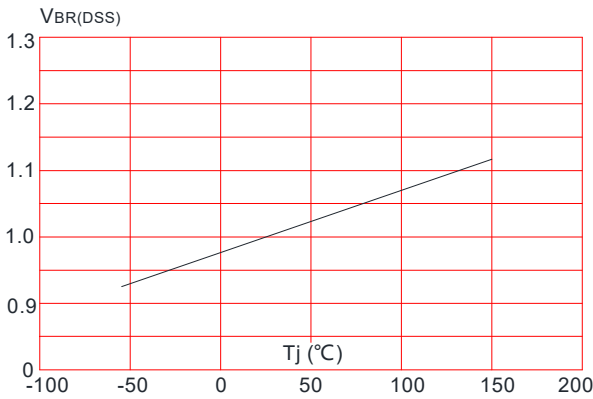


**Figure 6: Capacitance Characteristics**

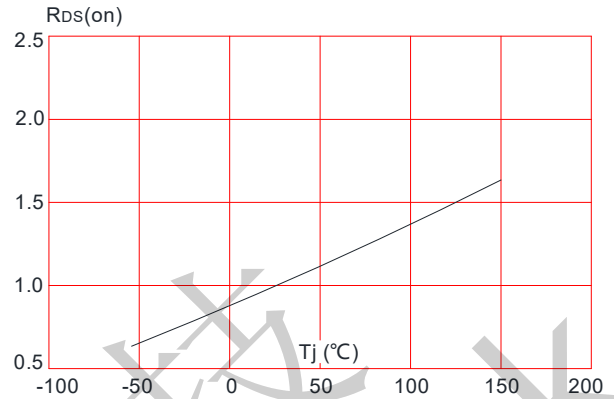




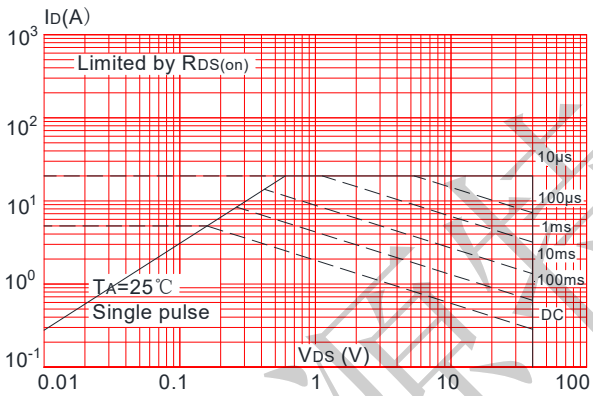
**Figure 7:** Normalized Breakdown Voltage vs. Junction Temperature



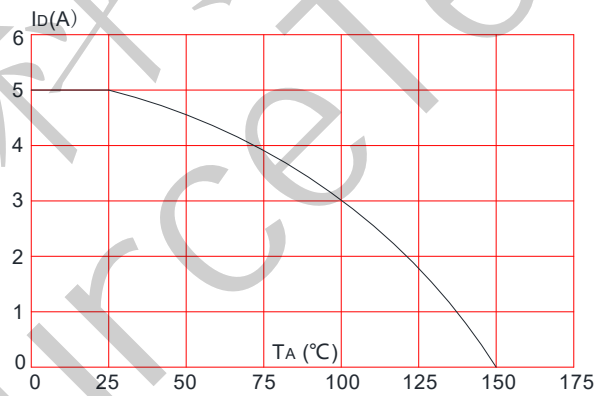
**Figure 8:** Normalized on Resistance vs. Junction Temperature



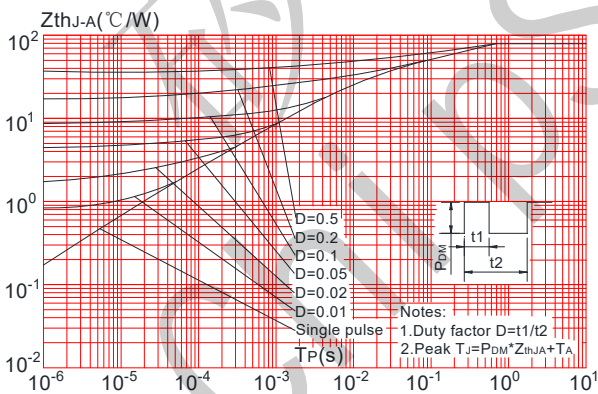
**Figure 9:** Maximum Safe Operating Area



**Figure 10:** Maximum Continuous Drain Current vs. Ambient Temperature

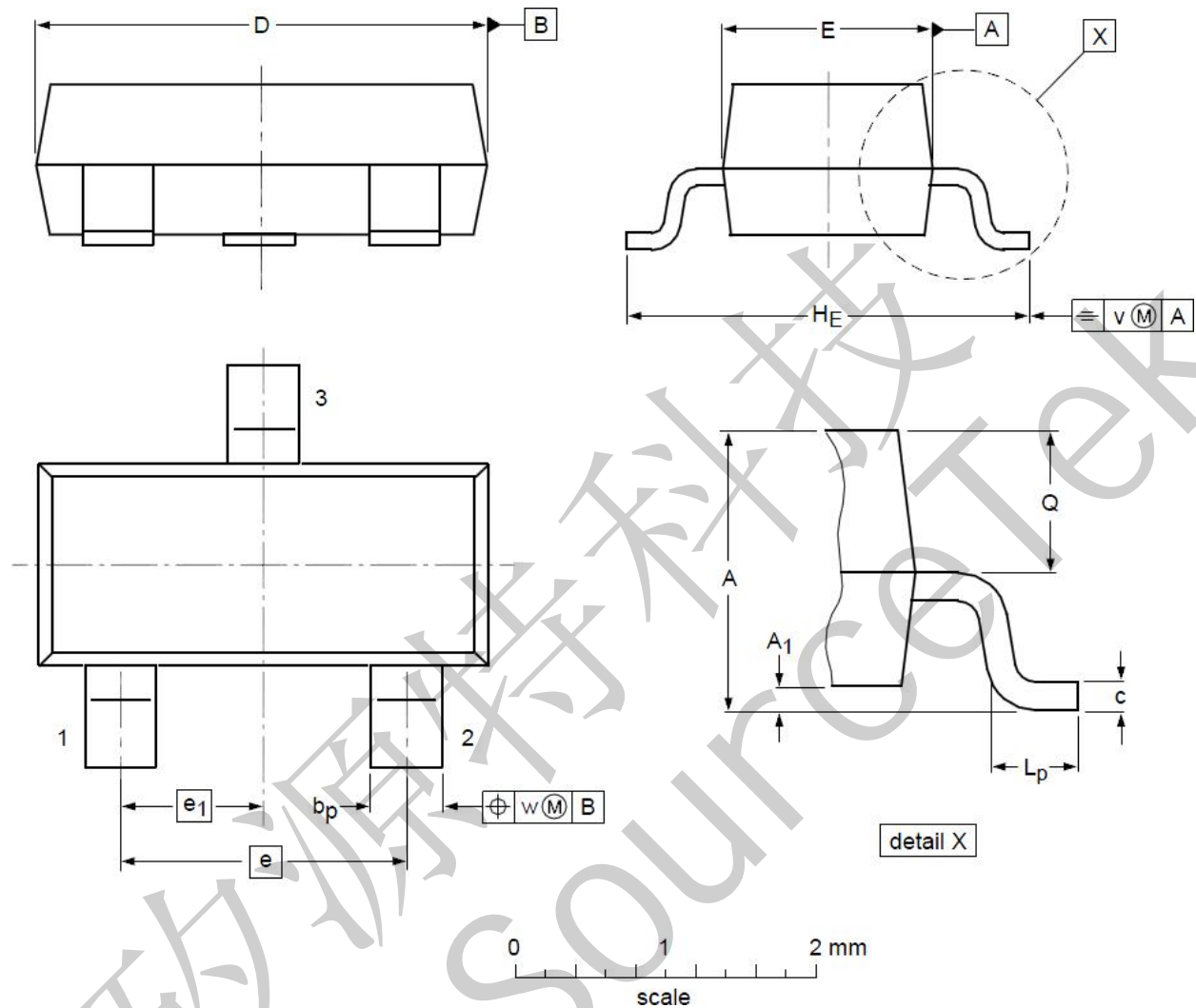


**Figure.11:** Maximum Effective Transient Thermal Impedance, Junction-to-Ambient





CST2318 SOT23 Mechanical Data



DIMENSIONS ( unit : mm )

Symbol	Min	Typ	Max	Symbol	Min	Typ	Max
A	0.90	1.01	1.15	A <sub>1</sub>	0.01	0.05	0.10
b <sub>p</sub>	0.30	0.42	0.50	c	0.08	0.13	0.15
D	2.80	2.92	3.00	E	1.20	1.33	1.40
e	--	1.90	--	e <sub>1</sub>	--	0.95	--
H <sub>E</sub>	2.25	2.40	2.55	L <sub>p</sub>	0.30	0.42	0.50
Q	0.45	0.49	0.55	v	--	0.20	--
w	--	0.10	--				