



MOT8205 N-CHANNEL ENHANCEMENT

■ MOT8205 PRODUCT CHARACTERISTICS

VDSS	20V
$R_{DS(on)Typ}(@V_{GS}=2.5V)$	23m Ω
$R_{DS(on)Typ}(@V_{GS}=4.5V)$	17m Ω
Qg@type	8.4nC
ID	6A

Symbol

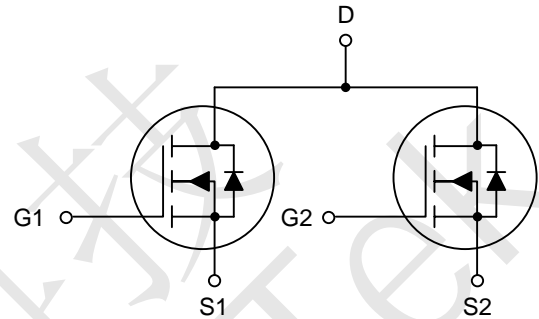

■ MOT8205 FEATURES

- * Fast switching capability
- * Avalanche energy Specified
- * Improved dv/dt capability, high ruggedness

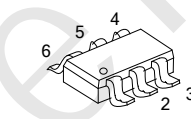

■ MOT8205 ORDER INFORMATION

Order codes		Package	Packing
Halogen-Free	Halogen		
N/A	MOT8205	SOT-23-6L	2500pieces/Reel

■ MOT8205 ABSOLUTE MAXIMUM RATINGS

PARAMETER	SYMBOL	RATINGS	UNIT	
Drain-Source Voltage	V_{DSS}	20	V	
Gate-Source Voltage	V_{GSS}	± 8	V	
Drain Current (Note 3)	Continuous	I_D	6	A
	Pulsed	I_{DM}	20	A
Power Dissipation ($T_A=25^\circ C$) (Note 2)	P_D	1.14	W	
Junction Temperature	T_J	+150	$^\circ C$	
Storage Temperature	T_{STG}	-55 ~ +150	$^\circ C$	

Notes: 1. Absolute maximum ratings are those values beyond which the device could be permanently damaged.

Absolute maximum ratings are stress ratings only and functional device operation is not implied.

2. Repetitive Rating: Pulse width limited by maximum junction temperature.

3. Pulse Test : Pulse width $\leq 300\mu s$, Duty cycle $\leq 2\%$.

■ MOT8205 THERMAL DATA

PARAMETER	SYMBOL	RATINGS	UNIT
Junction to Ambient	θ_{JA}	110	$^\circ C/W$

Note: Device mounted on FR-4 substrate PC board, 2oz copper, with 1inch square copper plate.



■ MOT8205 ELECTRICAL CHARACTERISTICS

PARAMETER	SYMBOL	TEST CONDITIONS	MIN	TYP	MAX	UNIT
OFF CHARACTERISTICS						
Drain-Source Breakdown Voltage	BV_{DSS}	$V_{GS}=0V, I_D=250\mu A$	20			V
Breakdown Voltage Temperature Coefficient	$\frac{\Delta BV_{DSS}}{\Delta T_J}$	$I_D=1mA$, Reference to 25°C		0.03		V/°C
Drain-Source Leakage Current	I_{DSS}	$V_{DS}=20V, V_{GS}=0V$,			1	μA
Gate-Source Leakage Current	I_{GSS}	$V_{GS}=\pm 8V$			± 100	nA
ON CHARACTERISTICS						
Gate Threshold Voltage	$V_{GS(TH)}$	$V_{DS}=V_{GS}, I_D=250\mu A$	0.5		1.5	V
Drain-Source On-State Resistance (Note)	$R_{DS(ON)}$	$V_{GS}=4.5V, I_D=6.0A$		17	24	m Ω
		$V_{GS}=2.5V, I_D=5.2A$		23	32	m Ω
DYNAMIC PARAMETERS						
Input Capacitance	C_{ISS}	$V_{DS}=20V, V_{GS}=0V, f=1.0MHz$		370		pF
Output Capacitance	C_{OSS}			78		pF
Reverse Transfer Capacitance	C_{RSS}			73		pF
SWITCHING PARAMETERS						
Total Gate Charge(Note)	Q_G	$V_{DS}=20V, V_{GS}=5V, I_D=6.0A$		8.4		nC
Gate Source Charge	Q_{GS}			1		nC
Gate Drain Charge	Q_{GD}			1.8		nC
Turn-ON Delay Time (Note)	$t_{D(ON)}$	$V_{GS}=5V, V_{DS}=10V, R_D=10\Omega, R_G=6\Omega, I_D=6A$		3.6		ns
Turn-ON Rise Time	t_R			2.7		ns
Turn-OFF Delay Time	$t_{D(OFF)}$			19		ns
Turn-OFF Fall-Time	t_F			7.6		ns
SOURCE- DRAIN DIODE RATINGS AND CHARACTERISTICS						
Drain-Source Diode Forward Voltage (Note)	V_{SD}	$I_S=1.7A, V_{GS}=0V$			1.2	V
Diode Continuous Forward Current	I_S	$V_D=V_G, V_S=1.3V$			1.54	A

Note: Pulse Test : Pulse width $\leq 300\mu s$, Duty cycle $\leq 2\%$.



■ MOT8205 TYPICAL CHARACTERISTICS(Cont.)

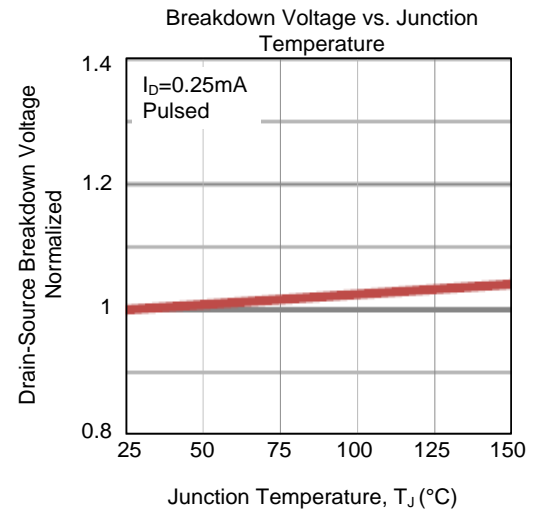
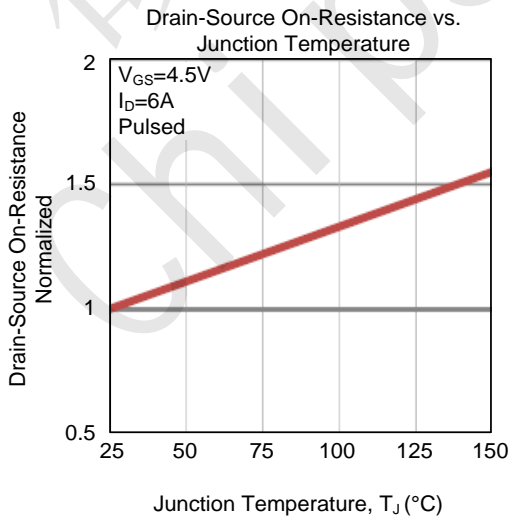
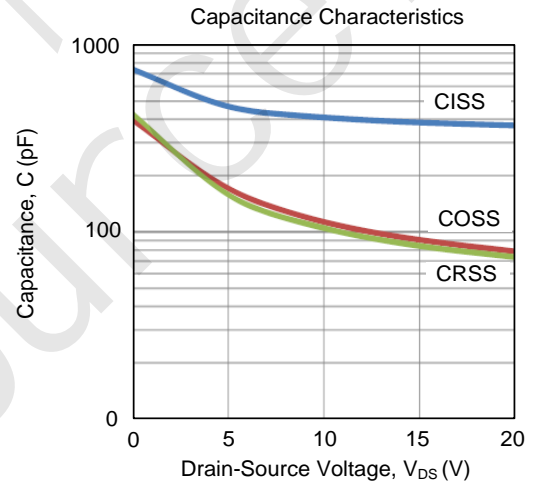
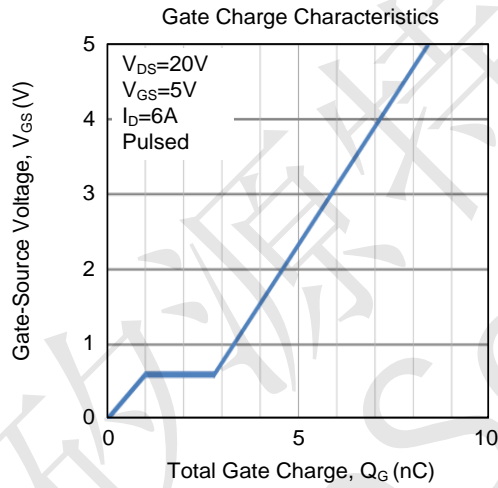
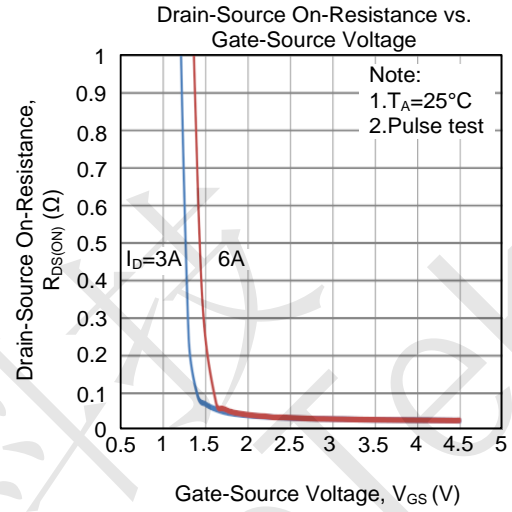
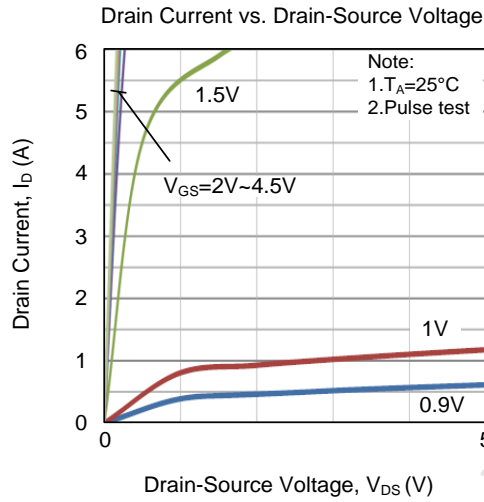



■ MOT8205 TYPICAL CHARACTERISTICS(Cont.)

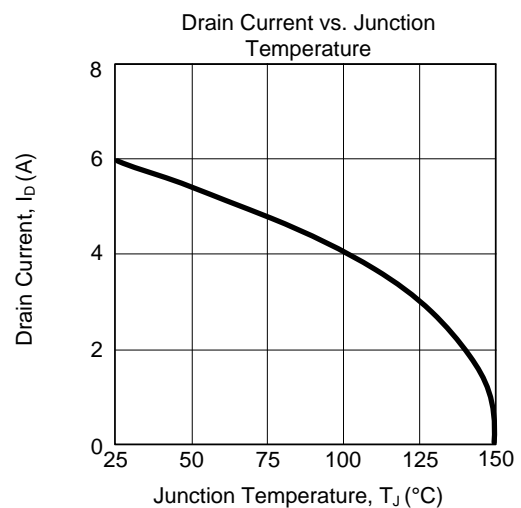
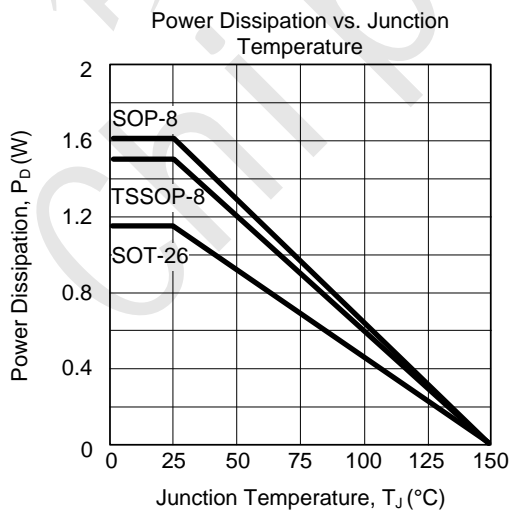
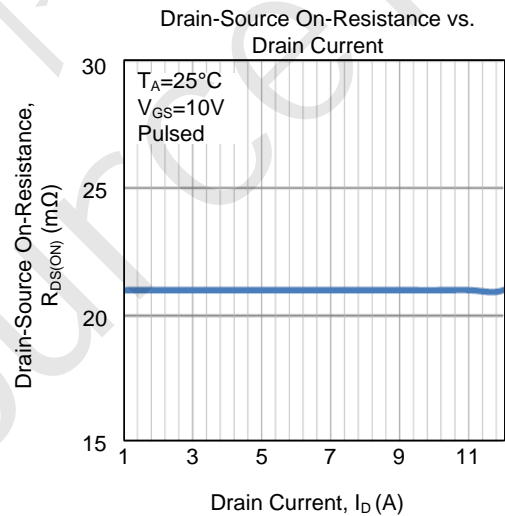
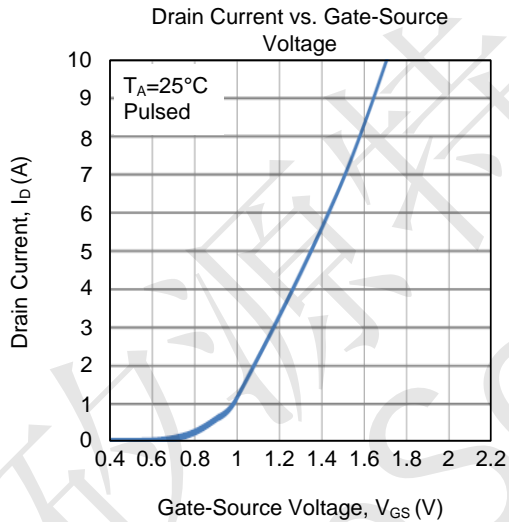
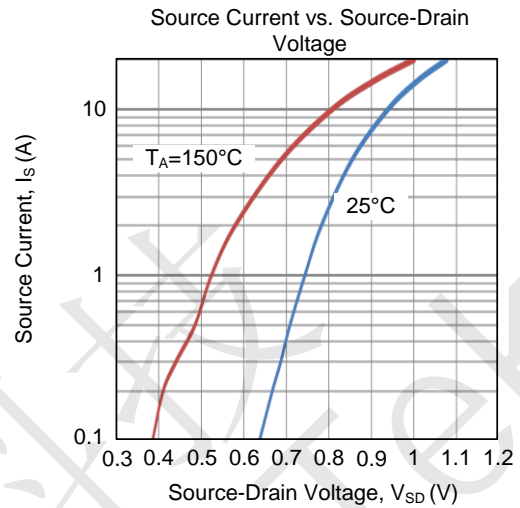
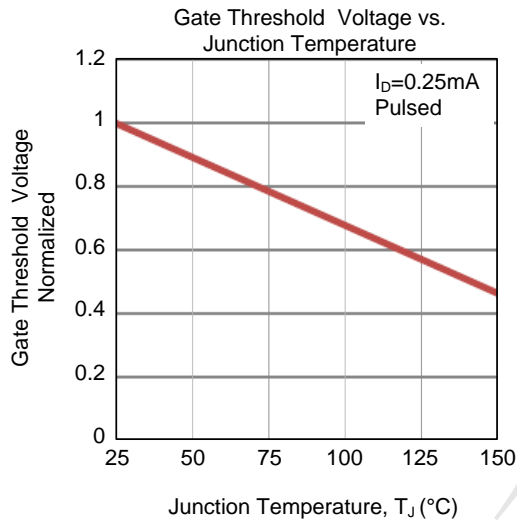



■ MOT8205 SOT23-6L PACKAGE OUTLINE DIMENSIONS

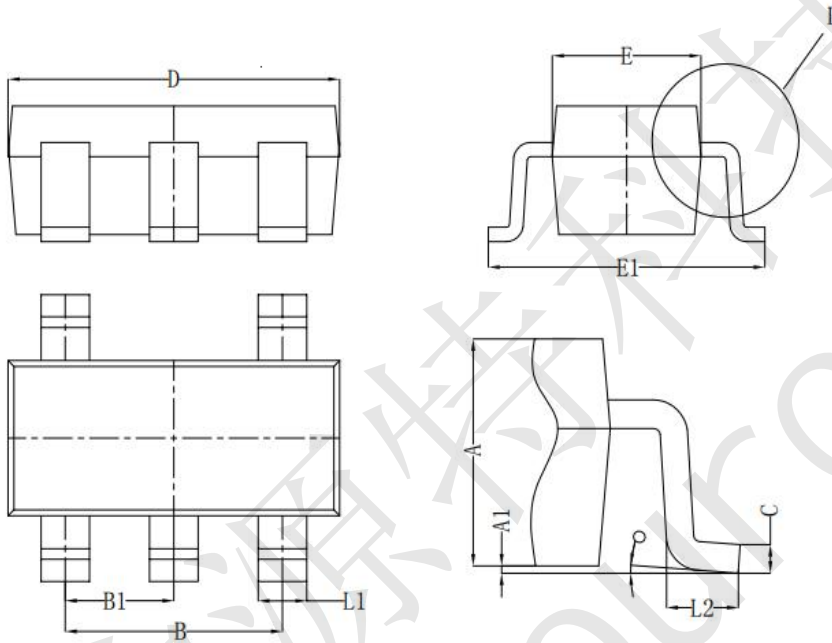

Symbol	Dim in mm		
	Min	Nor	Max
A	1.050	1.100	1.150
A1	0.000	0.050	0.100
L1	0.300	0.400	0.500
C	0.100	0.150	0.200
D	2.820	2.920	3.020
E	1.500	1.600	1.700
E1	2.650	2.800	2.950
B	1.800	1.900	2.000
B1	0.950 TYP		
L2	0.300	0.450	0.600
o	0°	4°	8°