



## FM86C0

## Switch with MIPI for LTE TRX

### Features

- Excellent insertion loss - 0.80dB Insertion Loss at 2.7GHz
- P0.1dB = 34dBm
- Multi-Band operation 700MHz to 3000MHz
- RFFE serial control interface
- Compact 2.5mm x 2.5mm in QFN-20 package
- No DC blocking capacitors required (unless external DC is applied to the RF ports)

### Applications

- 2G/3G/4G antenna TRX Application
- Cellular modems and USB Devices

switch for antenna TRX application.

The FM86C0 is compatible with MIPI control, which is a key requirement for many cellular transceivers. This part is packaged in a compact 2.5mm x 2.5mm, 20-pin, QFN package which allows for a small solution size with no need for external DC blocking capacitors (when no external DC is applied to the device ports).

### Functional Block Diagram and Pin Description

The FM86C0 is a low loss, high isolation SP12T

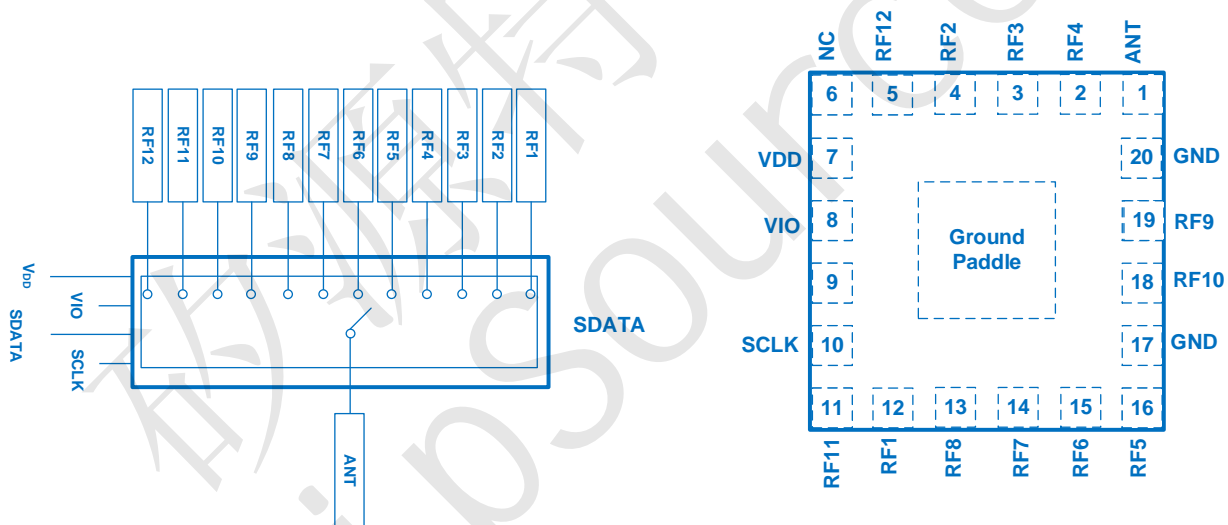

Figure 1 Functional Block Diagram and Pin Configuration



## FM86C0

## Switch with MIPI for LTE TRX

### Application Circuit

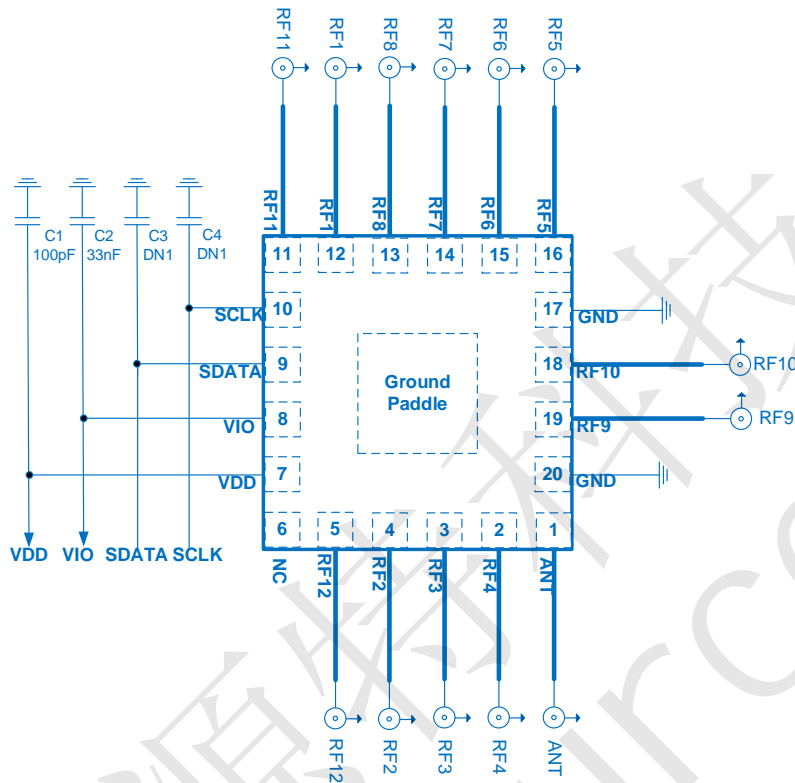

Figure 2 Evaluation Board Schematic

Table 1. Pin Description

Pin No.	Name	Description	Pin No.	Name	Description
1	ANT	Antenna port	11	RF11	RF port11
2	RF4	RF port4	12	RF1	RF port1
3	RF3	RF port3	13	RF8	RF port8
4	RF2	RF port2	14	RF7	RF port7
5	RF12	RF port12	15	RF6	RF port6
6	NC	Not Connect	16	RF5	RF port5
7	VDD	Power supply	17	GND	Ground
8	VIO	Supply voltage for MIPI	18	RF10	RF port10
9	SDATA	MIPI data input/output	19	RF9	RF port9
10	SCLK	MIPI clock	20	GND	Ground
Ground Paddle	GND	Ground			

Note: Bottom ground paddles must be connected to ground.



## FM86C0

## Switch with MIPI for LTE TRX

### Truth Table

Table 2.

State	Mode	Register_0							
		D7	D6	D5	D4	D3	D2	D1	D0
1	ISO	x	0	0	0	0	0	0	0
2	ISO	x	0	0	0	1	1	1	1
3	RF1 on	x	0	0	0	0	1	0	0
4	RF2 on	x	0	0	0	0	1	1	1
5	RF3 on	x	0	0	0	1	0	0	1
6	RF4 on	x	0	0	0	1	0	1	1
7	RF5 on	x	0	0	0	1	1	0	0
8	RF6 on	x	0	0	0	0	0	0	1
9	RF7 on	x	0	0	0	0	0	1	0
10	RF8 on	x	0	0	0	0	0	1	1
11	RF9 on	x	0	0	0	1	0	1	0
12	RF10 on	x	0	0	0	1	0	0	0
13	RF11 on	x	0	0	0	0	1	0	1
14	RF12 on	x	0	0	0	0	1	1	0

### Recommended Operation Range

Table 3. Recommended Operation Condition

Parameters	Symbol	Min	Typ	Max	Units
Operation Frequency	f1	0.7	-	3.0	GHz
Power supply	VDD	2.5	2.8	3.6	V
Power supply for MIPI	VIO	1.65	1.8	1.95	V
MIPI Control Voltage High	VH	0.8*VIO	1.8	1.95	V
MIPI Control Voltage Low	VL	0	0	0.3	V

### Specifications

Table 4. Electrical Specifications

Parameter	Symbol	Test Condition	Min	Typical	Max	Units
<b>DC Specifications</b>						
Supply voltage	V <sub>DD</sub>		2.5	2.8	3.0	V
Supply current	I <sub>DD</sub>			100	150	uA
V <sub>IO</sub> supply voltage	V <sub>IO</sub>		1.65	1.8	1.95	V
V <sub>IO</sub> Supply current	I <sub>IO</sub>			4	10	uA



## FM86C0

## Switch with MIPI for LTE TRX

SDATA, SCLK control voltage: High Low	VCTL_H VCTL_L		0.8* V <sub>IO</sub> 0	V <sub>IO</sub> 0	1.95 0.3	V V
Switching Speed, one RF to another		10% to 90% RF		2	3	uS
RF Specifications						
Insertion loss (ANT pin to RF1/2/3/4/5/6/7/8/9/10/11/12 pins)	IL	0.1 to 1.0 GHz		0.60		dB
		1.0 to 2.0 GHz		0.70		dB
		2.0 to 2.7 GHz		0.80		dB
Isolation (ANT pin to RF1/2/3/4/5/6/7/8/9/10/11/12 pins)	Iso	0.1 to 1.0 GHz	35	40		dB
		1.0 to 2.0 GHz	25	30		dB
		2.0 to 2.7 GHz	18	20		dB
Input return loss (ANT pin to RF1/2/3/4/5/6/7/8/9/10/11/12 pins)	RL	0.1 to 1.0 GHz	20	25		dB
		1.0 to 2.0 GHz	15	20		dB
		2.0 to 2.7 GHz	12	15		dB
0.1 dB Compression Point (ANT pin to RF1/2/3/4/5/6/7/8/9/10/11/12 pins)	P0.1dB	0.7 GHz to 3.0 GHz		+34		dBm

### MIPI Read and Write Timing

MIPI supports the following Command Sequences:

- Register Write
- Register\_0 Write
- Register Read

Figures 3 and 4 provide the timing diagrams for register write commands and read commands, respectively. Figure 5 shows the Register 0 Write Command Sequence. Refer to the MIPI Alliance Specification for RF Front-End Control Interface (RFFE), v1.10 (26 July 2011) for additional information on MIPI USID programming sequences and MIPI bus specifications.

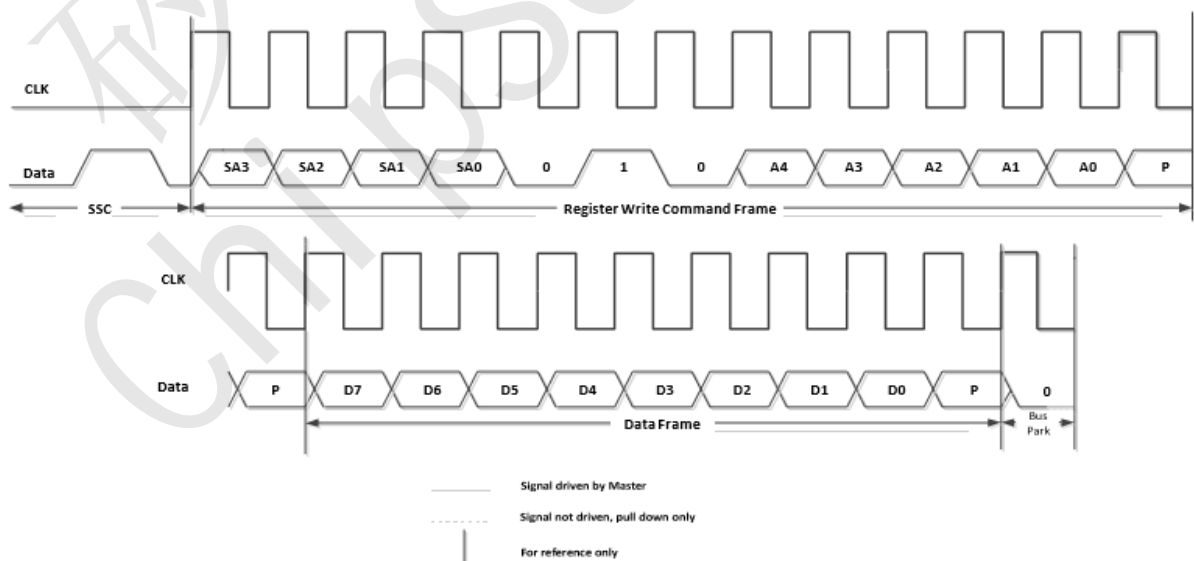
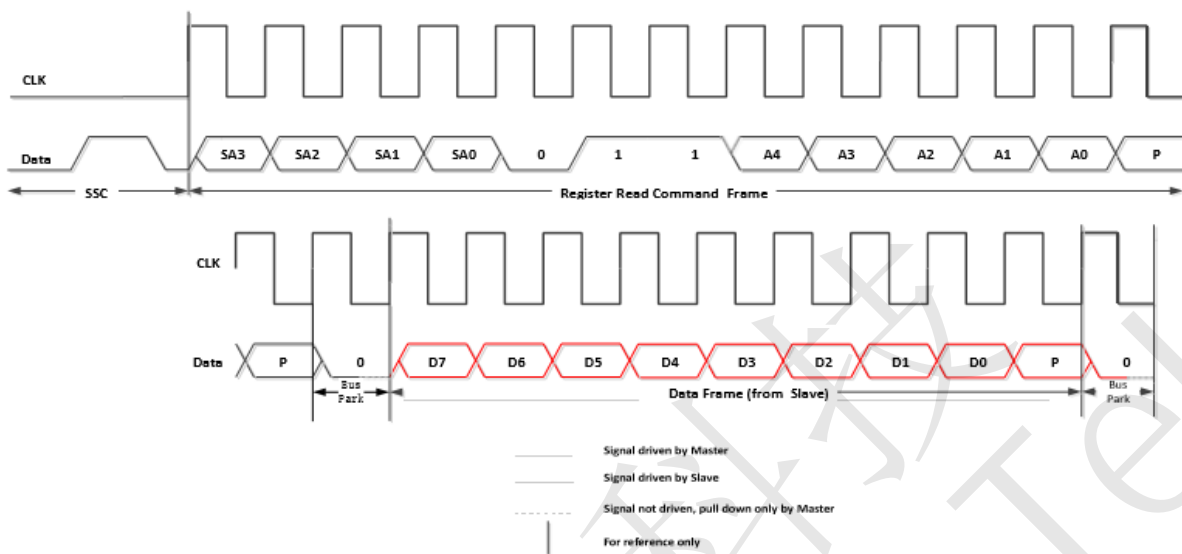

Figure 3 Register Write Command Sequence



## FM86C0

## Switch with MIPI for LTE TRX



In the timing figures, SA[3:0] is slave address. A[4:0] is register address. D[7:0] is data. "P" is odd parity bit.

### Register 0 Write Command Sequence

Figure shows the Register 0 Write Command Sequence. The Command Sequence starts with an SSC, followed by the Register 0 Write Command Frame containing the Slave address, a logic one, and a seven bit word to be written to Register 0. The Command Sequence ends with a Bus Park Cycle

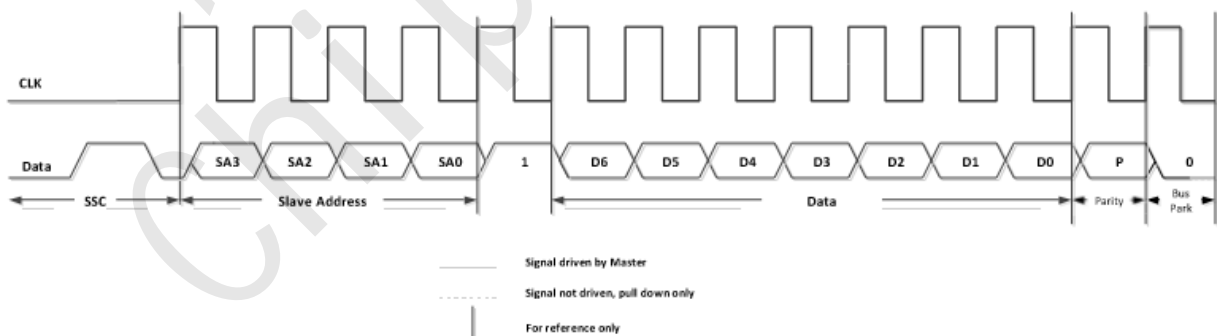



## FM86C0

## Switch with MIPI for LTE TRX

### Register definition

Table 5. Register definition table

Register Address	Register Name	Data Bits	R/W	Function	Description	Default	BROADC AST_ID support	Trigger support
0x00	REGISTER_0	7:0	R/W	RF Control	Register_0 truth Table: Table 2	0x00	No	Yes
0x001B	GROUP_SID	7:4	R	RESERVED		0x0	No	No
		3:0	R/W	GSID	Group Slave ID	0x0	No	No
0x001C	PM_TRIG	7:6	R/W	PWR_MODE	00: Normal Operation (ACTIVE) 01: Reset all registers to default settings (STARTUP) 10: Low power (LOW POWER) 11: Reserved Note: Write PWR_MODE=2'h1 will reset all register, and puts the device into STARTUP state.	0b10	Yes	No
		5	R/W	Trigger_Mask_2	If this bit is set, trigger 2 is disabled	0	No	No
		4	R/W	Trigger_Mask_1	If this bit is set, trigger 1 is disabled	0	No	No
		3	R/W	Trigger_Mask_0	If this bit is set, trigger 0 is disabled Note: When all triggers are disabled, writing to a register that is associated with trigger 0, 1, or 2, causes the data to go directly to the destination register.	0	No	No
		2	W	Trigger_2	A write of a one to this bit loads trigger 2's registers	0	Yes	No
		1	W	Trigger_1	A write of a one to this bit loads trigger 1's registers	0	Yes	No
		0	W	Trigger_0	A write of a one to this bit loads trigger 0's registers Note: Trigger processed immediately then cleared. Trigger 0, 1, and 2 will always read as 0.	0	Yes	No
		0x001D	PRODUCT_ID	7:0	R	PRODUCT_ID	Product Number	0x5F
0x001E	MANUFACTURER_ID	7:0	R	MANUFACTURER_ID[7:0]	Lower eight bits of MIPI registered Manufacturer ID	0x78	No	No
0x001F	MAN_USID	7:6	R	RESERVED		0b00	No	No
		5:4	R	MANUFACTURER_ID[9:8]	Upper two bits of MIPI registered Manufacturer ID	0b4	No	No
		3:0	R/W	USID	USID of the device.	0xA	No	No



## FM86C0

## Switch with MIPI for LTE TRX

### Absolute Maximum Ratings

Table 6. Maximum ratings

Parameters	Symbol	Minimum	Maximum	Units
Supply voltage	V <sub>DD</sub>	+1.6	+4.2	V
Supply voltage for MIPI	V <sub>IO</sub>	+1.0	+2.0	V
MIPI Control voltage (SDATA, SCLK)	V <sub>CTL</sub>	0	+2.0	V
RF input power	P <sub>IN</sub>		+36	dBm
Operating temperature	T <sub>OP</sub>	-20	+85	°C
Storage temperature	T <sub>STG</sub>	-40	+125	°C
Electrostatic Discharge Human body model (HBM), Class 1C	ESD_HBM		1000	V
Machine Model (MM), Class A	ESD_MM		100	
Charged device model (CDM), Class III	ESD_CDM		1000	

**Note:** Exposure to maximum rating conditions for extended periods may reduce device reliability. There is no damage to device with only one parameter set at the limit and all other parameters set at or below their nominal value. Exceeding any of the limits listed here may result in permanent damage to the device

### Power ON and OFF sequence

Here is the recommendation about power-on/off sequence in order to avoid damaging the device.

#### Power ON

- 1) Apply voltage supply - V<sub>DD</sub>
- 2) Apply logic supply - V<sub>IO</sub>
- 3) Wait 10μs or greater and then apply MIPI bus signals – SCLK and SDATA
- 4) Wait 5μs or greater after MIPI bus goes idle and then apply the RF Signal

#### Power OFF

- 5) Remove the RF Signal
- 6) Remove MIPI bus – SCLK and SDATA
- 7) Remove logic supply - V<sub>IO</sub>
- 8) Remove voltage supply - V<sub>DD</sub>



## FM86C0

## Switch with MIPI for LTE TRX

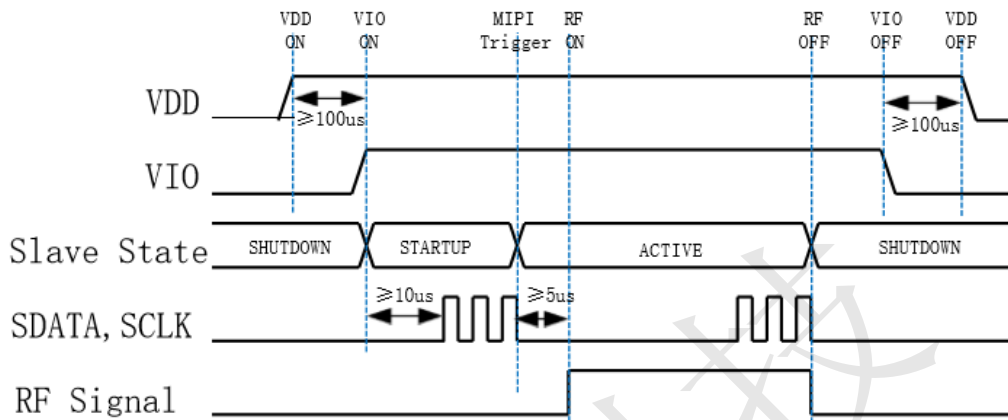

**Note:** VIO can be applied to the device before VDD or removed after VDD.

It is important to wait  $10\mu s$  after VIO & VDD are applied before sending SDATA to ensure correction data transmission. The minimum time between a power up and power down sequence (and vice versa) is  $\geq 100\mu s$ .





## FM86C0

## Switch with MIPI for LTE TRX

### Reflow Chart

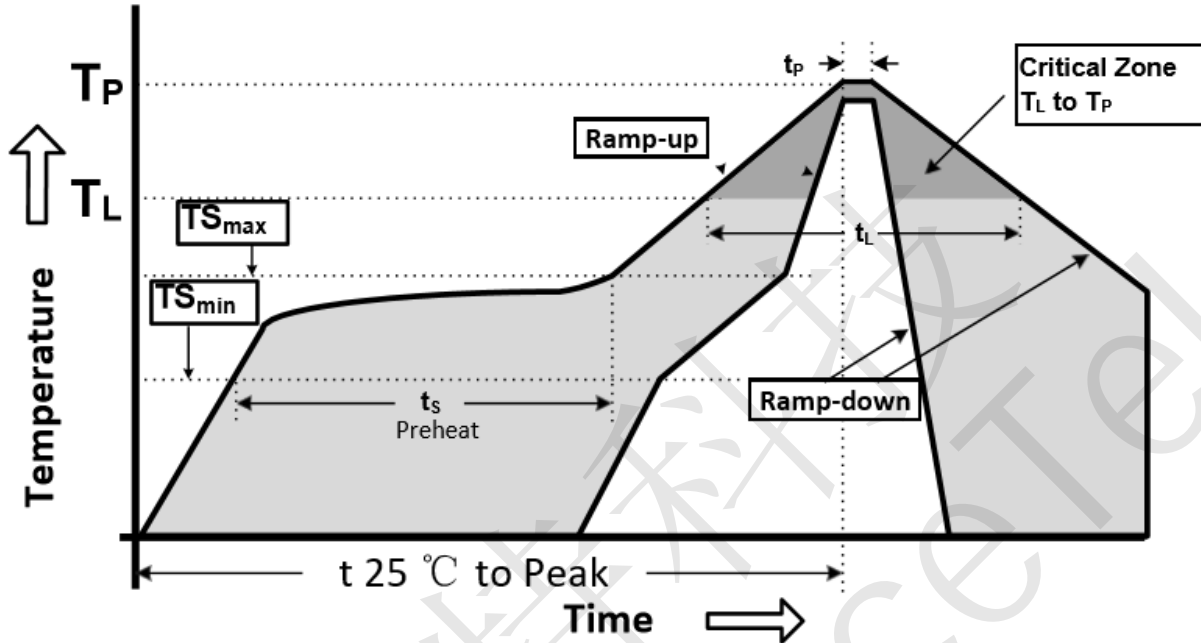

Figure 7 Recommended Lead-Free Reflow Profile

Table 7. Reflow condition

Profile Parameter	Lead-Free Assembly, Convection, IR/Convection
Ramp-up rate ( $T_{S_{max}}$ to $T_p$ )	3°C/second max.
Preheat temperature ( $T_{S_{min}}$ to $T_{S_{max}}$ )	150°C to 200°C
Preheat time ( $t_s$ )	60 - 180 seconds
Time above $T_L$ , 217°C ( $t_L$ )	60 - 150 seconds
Peak temperature ( $T_p$ )	260°C
Time within 5°C of peak temperature( $t_p$ )	20 - 40 seconds
Ramp-down rate	6°C/second max.
Time 25°C to peak temperature	8 minutes max.

### ESD Sensitivity

Integrated circuits are ESD sensitive and can be damaged by static electric charge. Proper ESD protection techniques should be used when handling these devices.

### RoHS Compliant

This product does not contain lead, mercury, cadmium, hexavalent chromium, polybrominated biphenyls (PBB) and polybrominated diphenyl ethers (PBDE), and are considered RoHS compliant.