



DW01B

One-cell LithiumBattery Protection IC

◆◆ General Description 概述

The DW01B battery protection IC is designed to protect lithium-ion / polymer battery from damage or degrading the lifetime due to over current for one-cell lithium-ion / polymer battery powered systems. such as cellular phones.

The ultra-small package and less required external components make it ideal to integrate the DW01B into the limited space of battery pack. The accurate $\pm 50\text{mV}$ overcharging detection voltage ensures safe and full utilization charging. The very low standby current drains little current from the cell while in storage.

DW01B 电池保护 IC 是专为保护锂离子/锂聚合物电池损坏，或因过电流使用而降低寿命之锂电池保护系统。诸如蜂窝电话。

DW01B 使用超小型封装，减少所需的外部组件；非常适用于空间有限的电池组。准确的 $\pm 50\text{mV}$ 的过充电检测电压，确保安全和充分充电。及储存时极低的待机电流。

◆◆ Features 特点

➤ High-accuracy voltage detection circuit 高精度电压检测电路

Overcharge detection voltage 过充电检测电压	3.6V to 4.4V	Accuracy 精度 $\pm 50\text{mV}$
Overcharge release voltage 过充电解除电压	3.6V to 4.4V	Accuracy 精度 $\pm 50\text{mV}$
Overdischarge detection voltage 过放电检测电压	2.0V to 3.0V	Accuracy 精度 $\pm 75\text{mV}$
Overdischarge release voltage 过放解除电压	2.0V to 3.4V	Accuracy 精度 $\pm 75\text{mV}$
Discharge overcurrent detection voltage 过放电流检测电压	0.05V to 0.3V	Accuracy 精度 $\pm 20\text{mV}$
Battery short-circuiting detection voltage 电池短路检测电压	0.82V to 1.75V	Accuracy 精度 $\pm 100\text{mV}$

➤ Detection delay times are generated by an internal circuit

(external capacitors are unnecessary)

内置延迟电路，不需要外接电容即具有延迟保护的功能

Overcharge detection delay time 过充电检测延迟时间	Typical. 典型值 110ms
Overdischarge detection delay time 过放电检测延迟时间	Typical. 典型值 55ms
Discharge overcurrent detection delay time 过放电流检测延迟时间	Typical. 典型值 7ms
Battery short-circuiting detection delay time 电池短路检测延迟时间	Typical. 典型值 400 μs



DW01B

One-cell LithiumBattery Protection IC

- High voltage tolerance is used for charger connection pins, VM and CO pins are absolute maximum rating=28V

充电器充电端子 VM 端子与 CO 端子采用高压元器件设计，额定电压值为 28V

- 0V battery charge function available

可选择向 0V 电池充电功能或是禁止 0V 电池充电功能

- Wide operation temperature range

宽工作温度范围

-40 ~ +85°C

- Low current consumption

低消耗电流

Operation mode

Typ. 2.0 μ A

正常操作

Max. 6.0 μ A (25°C)

Standby mode

Green-mode

Max. 0.7 μ A (25°C)

待机电流

休眠功能

Self-recovery function

Max. 3.0 μ A (25°C)

自恢复功能

- Small package

超小型封装

SOT-23-6L

- Lead-free / Green product

无铅 / 绿色产品封装

◆◆ Applications 应用

- Protection IC for One-Cell Lithium-ion

单节锂电池保护电路

- Lithium-Polymer Rechargeable Battery Packs

锂离子电池保护电路



DW01B

One-cell Lithium Battery Protection IC

◆◆ Block Diagram 内部结构图

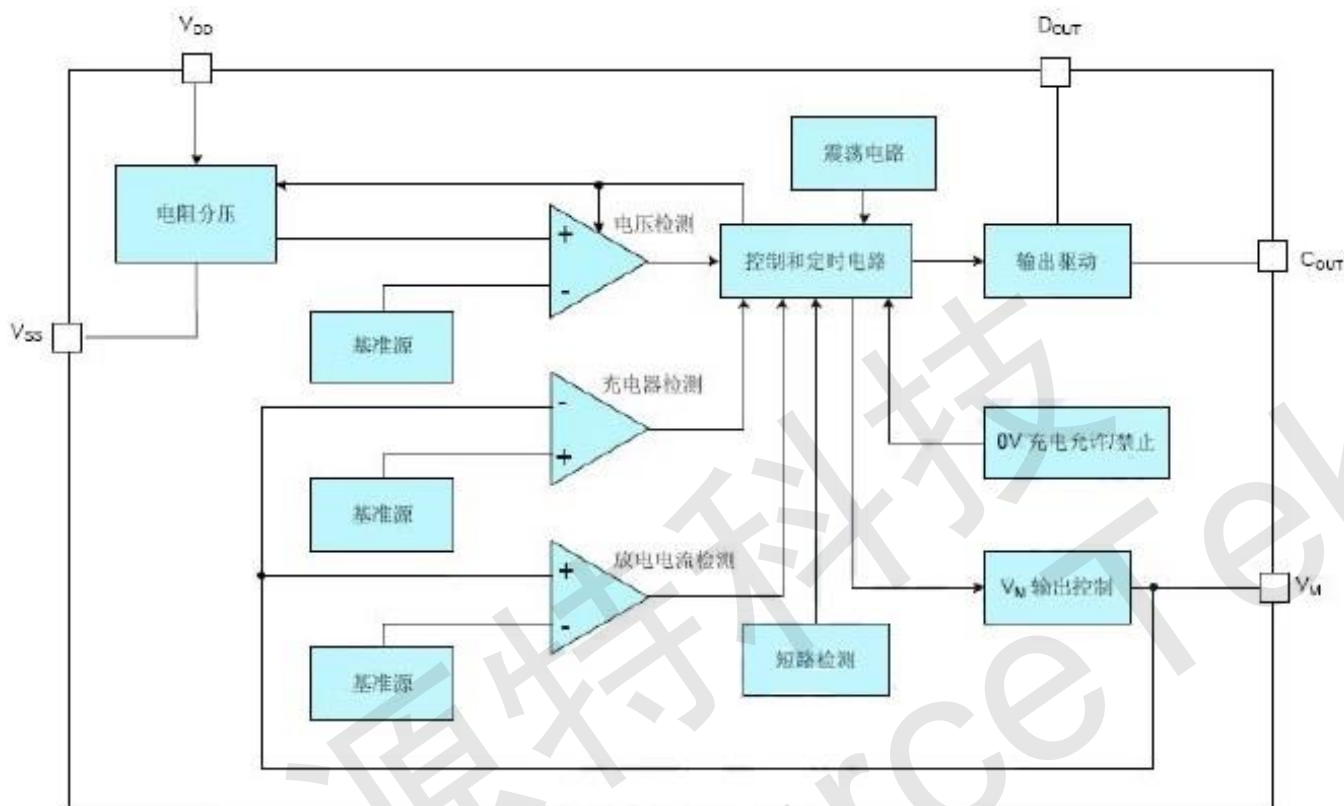

◆◆ Absolute Maximum Ratings

绝对最大额定值

(无特殊标注时 $V_{SS}=0V$, $T_a=25^{\circ}C$ unless otherwise specified)

Item 项目	Symbol 符号	Rating 参数范围	Unit 单位
Input voltage between VDD and VSS 电源电压	VDD	$V_{SS} - 0.3 \sim V_{SS} + 10$	V
VM pin input voltage VM 端输入电压	VM	$V_{DD} - 28 \sim V_{DD} + 0.3$	V
DO pin output voltage DO 端输出电压	VDO	$V_{SS} - 0.3 \sim V_{DD} + 0.3$	V
CO pin output voltage CO 端输出电压	VCO	$V_{DD} - 28 \sim V_{DD} + 0.3$	V
Electrical static discharge 静电放电电压	HBM	2	KV
	MM	200	V
Operating Temperature Range 工作温度范围	TOPR	- 40 ~ + 85	$^{\circ}C$
Storage Temperature Range 储存温度范围	TSTG	- 55 ~ + 125	$^{\circ}C$

Remarks: Any operation condition exceeds the absolute maximum ratings will damage the IC.

附注：任何超过绝对最大额定值的操作条件，并不能保证芯片处于正常工作状态，并且会造成芯片劣化与损坏。



DW01B

One-cell LithiumBattery Protection IC

◆◆ Product Name List 产品电压版本

Product	Over charge Detection Voltage [Vdet1]	Over charge Release Voltage [Vrel1]	Over discharge Detection Voltage [Vdet2]	Over discharge Release Voltage [Vrel2]	Discharge overcurrent Detection Voltage [Vdet3]	0V Battery Charge Function	Mode Selection
产品名称	过充电检测电压	过充电解除电压	过放电检测电压	过放电解除电压	放电过电流检测电压	0V 充电	休眠功能
DW01B	4.3V±0.050V	4.1V±0.050V	2.5V±0.075V	2.9V±0.075V	150mV±20mV	Available 允许	Auto-recovery 自恢复

◆◆ Electrical Characteristics 电气参数 (无特殊标注时 TA = 25°C unless otherwise specified)

Item 项目	Symbol 符号	Test Condition 测试条件	Min. 最小值	Typ. 典型值	Max. 最大值	Unit 单位
Operating voltage between VDD & VSS VDD 与 VSS 端工作电压	VDDop		1.5	-	10.0	V
Between VM to VDD of the pull-up resistor VM 至 VDD 之间的上拉电阻	RVMD	VDD=1.8V, VM=0V Ta=25°C	100	300	900	KΩ
The pull-down resistor between VM to VSS VM 至 VSS 之间的下拉电阻	RVMS	Ta=25°C	15	30	45	KΩ
The COT output low pull-down resistor CO 输出低电平下拉电阻		Ta=25°C	-	4	-	MΩ
CO pin Pch ON voltage CO Pch ON 电压	VCOH	VDD=3.9V, Ta=25°C Ico=10uA	VDD-0.4	VDD-0.2	-	V
DO pin Nch ON voltage DO Nch ON 电压	VDOL	VDD=2.0V, Ta=25°C Ico=10uA	-	0.2	0.4	V
DO pin Pch ON voltage DO Pch ON 电压	VDOH	VDD=3.9V, Ta=25°C Ico=10uA	VDD-0.4	VDD-0.2	-	V
Current consumption 正常操作消耗电流	IDD	VDD=3.9V, VM=0V	-	2.0	6.0	uA
A low power consumption mode the quiescent current 低功耗模式静态电流	IPDWN	VDD=2.0V		0.7	1.0	uA



DW01B

One-cell LithiumBattery Protection IC

◆◆ Electrical Characteristics 电气参数 (无特殊标注时 TA = 25°C unless otherwise specified)

DETECTION VOLTAGE 检测电压

Item 项目	Symbol 符号	Test Condition 测试条件	Min. 最小值	Typ. 典型值	Max. 最大值	Unit 单位
Overcharge detection voltage 过充电检测电压	Vdet1	R1=100Ω	4.250	4.300	4.350	V
Overcharge release voltage 过充电解除电压	Vrel1	R1=100Ω	4.050	4.100	4.150	V
Overcharge hysteresis voltage 过充电滞后电压	Vhys1	R1=100Ω Vhys1=Vdet1-Vrel1	-	0.200	-	V
Overdischarge detection voltage 过放电检测电压	Vdet2	VM=0V,R1=100Ω	2.425	2.500	2.575	V
Overdischarge release voltage 过放解除电压	Vrel2	R1=100Ω	2.825	2.900	2.975	V
Discharging overcurrent detection voltage 过放电流检测电压	Vdet3	VDD=3.0V, R2=1.0kΩ	0.130	0.150	0.170	V
Short detection voltage 负载短路检测电压	Vshort	VDD=3.0V	0.820	1.360	1.750	V
Charger detection voltage 充电器检测电压	Vchg	VDD=3.0V, Ta=25°C	-0.27	-0.5	-0.86	V
0V charging allowed voltage threshold 0V 充電允許電壓值 (0V charging allowed type) (0V 充電允許型號)	V0V_chg	Ta=25°C	1.2	-	-	V
0V charging prohibition voltage threshold 0V 充電禁止電壓值 (0V charging prohibition type) (0V 充電禁止型號)	V0V_inh	VM=2.0V Ta=25°C	-	-	1.2	V



DW01B

One-cell LithiumBattery Protection IC

◆◆ Electrical Characteristics 电气参数 (无特殊标注时 TA = 25°C unless otherwise specified)

DELAY TIME 延迟时间

Item 项目	Symbol 符号	Test Condition 测试条件	Min. 最小值	Typ. 典型值	Max. 最大值	Unit 单位
Overcharge detection delay time 过充电检测延迟时间	TVdet1	VDD=3.6V→4.4V	80	110	150	ms
Overcharge release delay time 过充电解除延迟时间	TVrel1	VDD=4.4V→3.6V	-	0.7	-	ms
Overdischarge detection delay time 过放电检测延迟时间	TVdet2	VDD=3.6V→2.4V	38.5	55	71.5	ms
Overdischarge release delay time 过放电解除延迟时间	TVrel2	VDD=2.4V→3.6V	-	0.7	-	ms
Discharging overcurrent detection delay time 过放电电流检测延迟时间	TVdet3	VDD=3.0V, VM=0V→0.2V	5	10	20	ms
Discharging overcurrent release delay time 过放电电流解除延迟时间	TVrel3	VDD=3.0V, VM=0.2V→0V	-	0.7	-	ms
Over current discharge protection delay time 过电流放电保护延迟时间	TEDI	Ta=25°C	5	7	9	ms
Over current discharge recovery delay time 过电流放电恢复延迟时间	TEDIR	Ta=25°C	1.2	1.8	2.4	ms
Short detection delay time 负载短路检测延迟时间	Tshort	VDD=3.5V, VM=0V→1.0V	100	300	500	us
Charger detection voltage 充电器检测电压	Vchg	VDD=3.0V, Ta=25°C	-0.27	-0.5	-0.86	V

◆◆ Pin Configuration and Package Marking Information 管脚描述

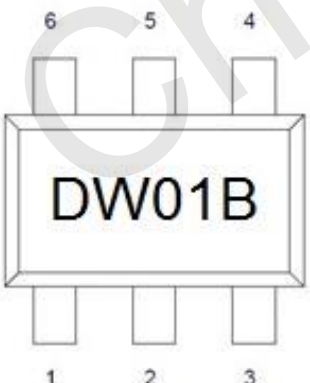
Package 封装型式	Pin No. 管脚号	Symbol 符号	Description 管脚描述
 <p style="text-align: center;">SOT-23-6L</p>	1	DO	Over-discharge MOSFET Gate control terminal 放电控制用 MOSFET 栅极连接端子
	2	VM	Input terminal connect to charger and system ground 输入端连接到充电器和系统接地
	3	CO	Over-charge MOSFET Gate control terminal 充电控制用MOSFET栅极连接端子
	4	NC	No connection 空脚
	5	VDD	Battery positive terminal 正电源输入端子
	6	VSS	Battery negative terminal 负电源输入端子



DW01B

One-cell LithiumBattery Protection IC

◆◆ Type Application Circuit 典型应用电路图

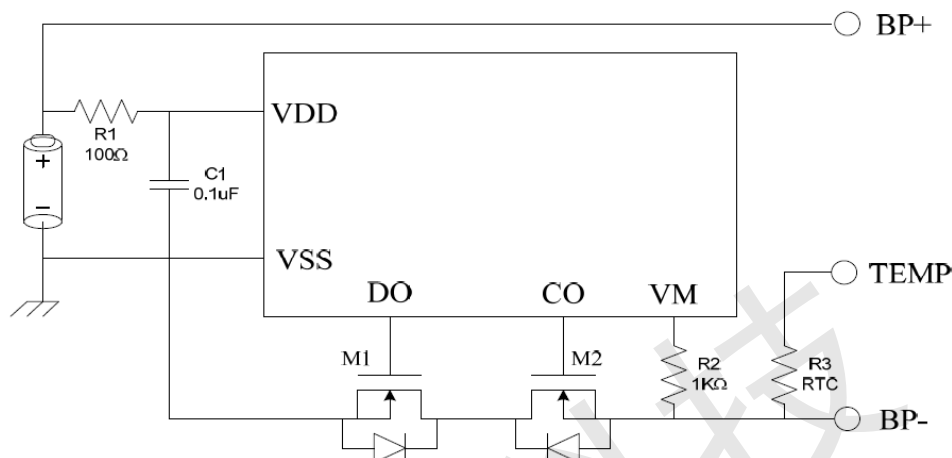

Symbol 符号	Components 器件名称	Function 功能	Min. 最小值	Typ. 典型值	Max. 最大值	Unit 单位	Remarks 备注
R1	Resistor 电阻器	Current limit noise filtering 限流与滤波稳压	-	100	1K	Ω	*1
R2	Resistor 电阻器	Current limit ESD protection 限流与静电保护	300	1K	2K	Ω	*4
R3	Thermistor 热敏电阻	Temp. protection 温度保护	-	-	-	kΩ	
C1	Capacitor 电容器	Noise filtering 滤波稳压	0.022	0.1	1.0	μF	*3
M1	N-MOSFET Nch 场效应管	Discharge switch 放电控制开关					*2
M2	N-MOSFET Nch 场效应管	Charge switch 充电控制开关					*2

*1: R1 is a single-stage RC filter, the higher resistance of R1, the better the filtering effect, If the R1 resistance higher than the recommended value, it will affect the internal detection circuit and the voltage detection accuracy will out of specification.

We suggest using the recommended resistance in application.

R1电阻主要提供一个单极的RC滤波器，R1的电阻愈高，滤波稳压的效果愈佳，若选择太高的R1，将影响内部分压电阻的阻抗，进而会影响过充电压与过放电压判断之精度，建议选择建议的电阻值。

*2: The absolute maximum rating of CO and VM is 28V, customer could choose 20V or 30V dual N-MOSFET switches for different application.

保护IC的耐压为28V，可选择业界常用的20V或是30V耐压的双N沟道MOS管。

*3: Add a C1 capacitor between VDD and VSS could filter conduction and radiation noise.

在VDD与VSS端间加一个C1电容，可滤除外界的传导与辐射噪声。

*4: R2 resistor could have a current limit function and limit charger current surge.

在R2处加一个电阻可以限制充电器瞬间的电流脉冲。



DW01B

One-cell LithiumBattery Protection IC

◆◆ Normal Operation 功能说明

The DW01B monitors the VDD power supply voltage relative to VSS detecting the over-charge and over-discharge conditions. It also monitors the VM voltage to detect the discharge over-current and load short circuiting to protect the battery cell. In normal operation, the VDD should be in the range from the over-charge detection voltage V_{det1} to the over-discharge voltage V_{det2} , and the VM pin voltage is in the range from discharge over-current voltage V_{det3} to charger detection voltage V_{chg} . In normal condition, the internal pull-up resistor (R_{VMD}) from VM pin to VDD is disconnected and the internal pull-down resistor (R_{VMS}) from VM pin to VSS is also disconnected.

DW01A可检测VDD到VSS的过充电压和过放电压情形。还可以监测VM的电压，并检测放电过电流和负载短路保护电池单元。在正常操作中，VDD应该在过充电检测电压 V_{det1} 的到过放电电压 V_{det2} 的范围内，并且VM电压的范围是从放电过电流电压 V_{det3} 到充电器检测电压 V_{chg} 。在正常情况下，从VM到VDD内部上拉电阻（ R_{VMD} ），或从VM和VSS内部下拉电阻（ R_{VMS} ）则也会关断。

Notice : Discharging may not be enacted when the battery is first time connected. To regain normal status, VM and VSS terminal must be shorted or the charger must be connected.

附记：当第一次连接电池的时候，有时不能进行放电。要恢复正常状态，将VM和VSS端子短路或将充电器连接上去即可恢复正常。

◆◆ Over-Charge Condition 过充电保护状态

When the battery voltage is greater than over-charge voltage (V_{det1}) and have a $T_{V_{det1}}$ time duration from a normal operation condition, the over-charge condition hold and the CO pin will output from logic "H" to logic "L" to disconnect the battery charging path. It will turn-off the external MOSFET and the charging status stopped.

当正常操作条件下，电池电压高于过充电电压（ V_{det1} ），延迟时间超过 $T_{V_{det1}}$ ，及过充电状态保持时，当CO端子电位从“H”到“L”，则会断开电池充电路径。这将关断外部MOSFET开关和终止充电。

It will release the over-charge condition in the following conditions. If the battery voltage less than V_{rel1} from the over-charge condition, the CO will output logic "H" to turn on the external MOSFET to resume the charging path. In the over-charge condition, the discharge over-current and load short circuiting function will be disabled until the battery voltage falls below the overcharge detection voltage.



DW01B

One-cell LithiumBattery Protection IC

It is because that the internal resistance of battery which will trigger the discharge over-current and load short circuiting function in the time when over-charge condition enabled.

在以下的条件，会停止过充电情况。如果在过充电情况下电池电压小于 V_{rel1} ，CO将输出为“H”，将打开外部MOSFET恢复充电路径。在过充电状态，放电过电流保护和负载短路保护的功能将启动，直到电池电压低于过充电检测电压才会恢复。这是由于当有过充电情况时，电池的内部电阻将会触发放电过电流保护和负载短路保护功能。

In over-charge condition, the internal pull-up resistor (R_{VMD}) from VM pin to VDD is disconnected and the internal pull-down resistor (R_{VMS}) from VM pin to VSS is also disconnected.

在过充电情况下，内部上拉电阻 (R_{VMD}) 从VM到VDD断开，及内部下拉电阻 (R_{VMS}) 从VM到VSS也断开。

◆◆ Over-Discharge Condition 过放电保护状态

The DW01B single-cell lithium protect IC monitors the VDD voltage to detect the over-discharge state from normal operation condition. If the VDD voltage becomes lower than the V_{det2} and continues for the over-discharge delay time T_{Vdet2} from normal operation condition, the DO pin will output “L” to disable the external MOSFET and the discharging stopped.

DW01B单节锂电池保护IC，在正常运行状态检测过放电保护状态。如果VDD电压低于 V_{det2} 电压下，DO端子电位为“L”，过放电延迟时间超过 T_{Vdet2} ，则关断外部MOSFET及停止放电。

If a charger is connected and the VDD voltage is greater than over-discharge release voltage V_{rel2} , the over-discharge condition released. In over-discharge condition, the charging path is connected by the parasitic diode of discharge controlled MOSFET.

如果连接充电器后VDD电压大于过放解除电压 V_{rel2} ，则为过放解除状态。在过放电状态下，充电路径连接是经由放电控制MOSFET的寄生二极管。



DW01B

One-cell LithiumBattery Protection IC

When a battery in the over-discharge condition, if VDD is greater than V_{rel2} and the VM is higher than V_{chg} , the over-discharge condition is released. When a battery in the over-discharge condition, if VDD is greater than V_{det2} and the VM is lower than V_{chg} , the over-discharge condition is released.

当电池处于过放电的状态，当VDD大于 V_{rel2} 及VM电压高于 V_{chg} ，过放电状态将解除。当VDD大于 V_{det2} 及VM电压低于 V_{chg} ，过放电状态将解除。

When the over-discharge condition hold, and the voltage difference between VM and VDD is less than 1.36V, the current consumption is reduced to the power-down current consumption 0.7 μ A in typical.

当过放电保护时，并且VM和VDD之间的电压差小于1.36V，Power-down消耗电流会降低到典型值0.7 μ A。

In over-discharge condition, the VM pin is connected to VDD by internal pull-up resistor (R_{VMD}) and the internal pull-down resistor (R_{VMS}) from VM pin to VSS is disconnected.

在过放电保护时，VM端子连接到VDD，通过内部上拉电阻(R_{VMD})和内部下拉电阻 (R_{VMS})从VM端子与VSS断开。

When the MOSFET is off, VM pin voltage is pulled up by the resistor to VDD in the IC, at this time, the power consumption is reduced to the lowest. This condition is called the "Green MODE".

当MOSFET关断时，电阻器到VDD会拉升VM端子的电压，在这段时间内，功耗减小到最低。这种情况被称为“绿色模式”。

◆◆ Over-current Condition 过电流保护

There are 3 kinds of over-current condition. One is the discharge over-current condition and another is the load short-circuiting condition and the other is charge over-current condition.

过电流有3种情况：一种是放电过电流情况，一种是在负载短路情况，而另一种是充电过电流情况。



DW01B

One-cell LithiumBattery Protection IC

The DW01B monitors the VM pin voltage to detect the over-current and load short-circuiting condition. If VM pin voltage is greater than V_{det3} and continues to discharge over-current delay time T_{Vdet3} , the over-current condition enabled and the DO pin output logic "L" to disable the discharging path. At the same time, the discharging is stopped.

DW01B监控VM的电压，来检测过电流和负载短路状态。如果VM电压大于 V_{det3} ，并超过放电过流延迟时间 T_{Vdet3} ，则启动过电流保护，DO输出电位为"L"关闭放电回路。同时停止放电。

In over-current condition, the internal pull-up resistor from VM pin to VDD (R_{VMD}) is disconnected and the VM pin is connected to VSS by internal pull-down resistor (R_{VMS}). However, the VM pin is pull-up to VDD by external load resistor. When the load is disconnected, the VM pin is pull-down to VSS by internal resistor.

在过电流状态下，VM到VDD内部上拉电阻 (R_{VMD})，及VM到VSS通过内部下拉电阻(R_{VMS})断开。然而，通过外部负载电阻VM上拉至VDD。当负载断开，通过内部电阻VM下拉到VSS。

If the VM pin voltage falls below the charger detection voltage V_{chg} under normal condition, and it continues and longer than the overcharge detection delay time T_{Vdet1} , the CO pin will disable the charging path by disconnected the charge controlled MOSFET. The charge over-current detection is released when the voltage difference between VM pin and VSS becomes less than charger detection voltage V_{chg} .

如果在正常情况下，VM电压低于充电器检测电压 V_{chg} ，并且时间超过过充电检测延迟时间 T_{Vdet1} ，CO将断开控制MOSFET停止充电。当VM和VSS之间的电压差，小于充电器检测电压 V_{chg} ，充电过流检测被解除。



DW01B

One-cell LithiumBattery Protection IC

◆◆ Timing Diagram

(1) Over-charge voltage detection/release & Over-discharge voltage detection/release

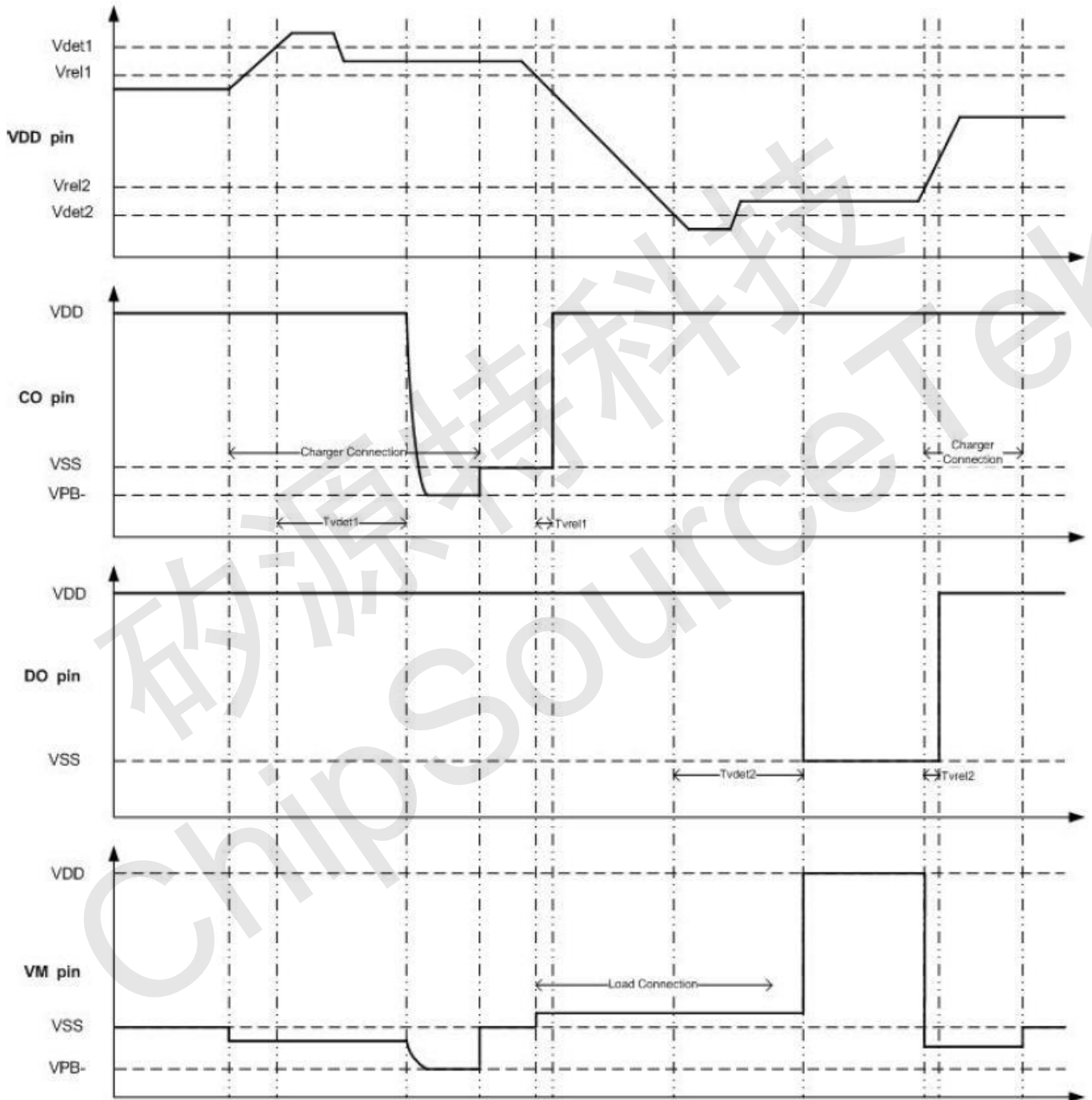



DW01B

One-cell LithiumBattery Protection IC

(2) Discharge over-current detection & Load short circuiting detection

