

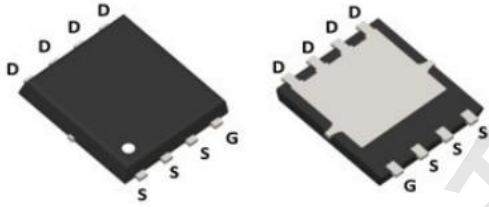
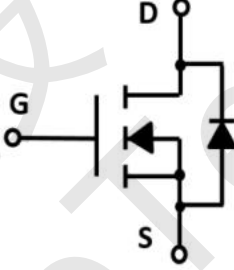

FMB6080G N-Channel Trench Power MOSFET

FMB6080G Description

Features <ul style="list-style-type: none"> • 60V,80A • $R_{DS(ON)}=5.9m\Omega$ (Typ.) @ $V_{GS}=10V$ • Advanced Trench Technology • Provide Excellent $R_{DS(ON)}$ and Low Gate Charge 	Application <ul style="list-style-type: none"> • LCD TV • Notebook • Elevator • Inductive heating • Power tools
Package <div style="display: flex; justify-content: space-around; align-items: center;"> <div style="text-align: center;">  <p>PDFN-8 (5*6)</p> </div> <div style="text-align: center;">  <p>Schematic diagram</p> </div> </div>	

FMB6080G Package Marking and Ordering Information

Product ID	PACK	Qty (pcs)
FMB6080G	PDFN-8(5*6)	4000

FMB6080G Absolute Maximum Ratings ($T_c=25^\circ\text{C}$ unless otherwise specified)

Symbol	Parameter	Value	Units
V_{DSS}	Drain-Source Voltage	60	V
V_{GSS}	Gate-Source Voltage	± 25	V
I_D	Continuous Drain Current	$T_c = 25^\circ\text{C}$	80
		$T_c = 100^\circ\text{C}$	36
I_{DM}	Pulsed Drain Current ^{note1}	170	A
E_{AS}	Single Pulsed Avalanche Energy ^{note2}	380	mJ
P_D	Power Dissipation	$T_c = 25^\circ\text{C}$	33.2
$R_{\theta JC}$	Thermal Resistance, Junction to Case	3.77	$^\circ\text{C}/\text{W}$
T_J, T_{STG}	Operating and Storage Temperature Range	-55 to +150	$^\circ\text{C}$



FMB6080G Electrical Characteristics (T_C=25°C unless otherwise specified)

Symbol	Parameter	Test Condition	Min.	Typ.	Max.	Units
Off Characteristic						
V _{(BR)DSS}	Drain-Source Breakdown Voltage	V _{GS} =0V, I _D =250μA	60	-	-	V
I _{DSS}	Zero Gate Voltage Drain Current	V _{DS} =48V, V _{GS} =0V,	-	-	1.0	μA
I _{GSS}	Gate to Body Leakage Current	V _{DS} =0V, V _{GS} =±25V	-	-	±100	nA
On Characteristics						
V _{GS(th)}	Gate Threshold Voltage	V _{DS} =V _{GS} , I _D =250μA	2.0	2.9	4.0	V
R _{DS(on)}	Static Drain-Source on-Resistance <small>note3</small>	V _{GS} =10V, I _D =20A	-	5.9	7.6	mΩ
g _{FS}	Forward Transconductance	V _{DS} =10V, I _D =20A	-	19	-	S
Dynamic Characteristics						
C _{iss}	Input Capacitance	V _{DS} =30V, V _{GS} =10V, f=1.0MHz	-	6208	-	pF
C _{oss}	Output Capacitance		-	511	-	pF
C _{rss}	Reverse Transfer Capacitance		-	438	-	pF
R _g	Gate resistance	-	-	2.2	-	Ω
Switching Characteristics						
Q _g	Total Gate Charge	V _{DS} =30V, I _D =20A, V _{GS} =10V	-	99.1	-	nC
Q _{gs}	Gate-Source Charge		-	22.3	-	nC
Q _{gd}	Gate-Drain("Miller") Charge		-	26.7	-	nC
V _{plateau}	Gate plateau voltage		-	4.5	-	V
t _{d(on)}	Turn-on Delay Time	V _{DS} =30V, V _{GS} =10V RL=1.5Ω, R _{GEN} =3Ω	-	25.7	-	ns
t _r	Turn-on Rise Time		-	93.7	-	ns
t _{d(off)}	Turn-off Delay Time		-	67.4	-	ns
t _f	Turn-off Fall Time		-	83.2	-	ns
Drain-Source Diode Characteristics and Maximum Ratings						
I _S	Maximum Continuous Drain to Source Diode Forward Current		-	-	80	A
I _{SM}	Maximum Pulsed Drain to Source Diode Forward Current		-	-	170	A
V _{SD}	Drain to Source Diode Forward Voltage	V _{GS} =0V, I _S =10A	-	-	1.2	V

- Notes: 1. Repetitive Rating: Pulse Width Limited by Maximum Junction Temperature
 2. EAS condition: T_J=25°C, V_{DD}=20V, V_G=10V, R_G=25Ω, L=0.5mH
 3. Pulse Test: Pulse Width≤300μs, Duty Cycle≤0.5%



FMB6080G Typical Performance Characteristics

Figure 1: On-Region Characteristics

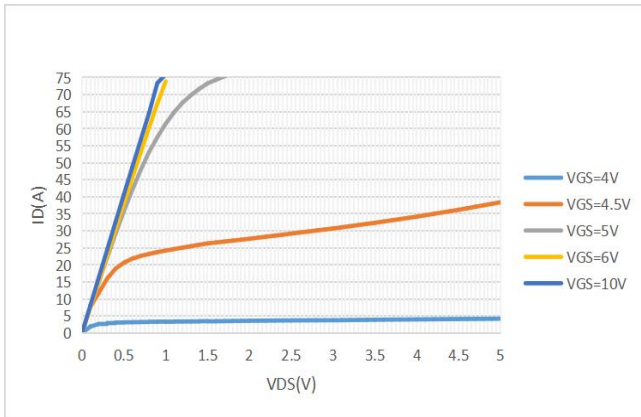

Figure 2: Transfer Characteristics

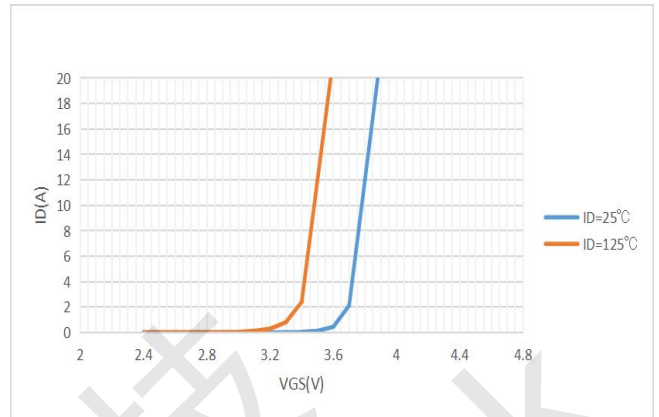

Figure 3: On-resistance vs. Drain Current and Gate Voltage

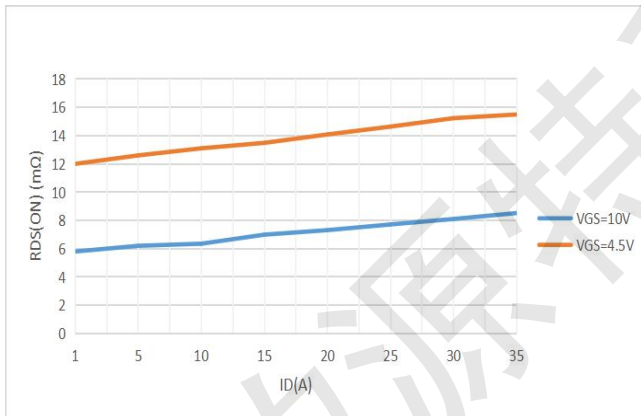

Figure 4: On-Resistance vs. Gate-Source Voltage

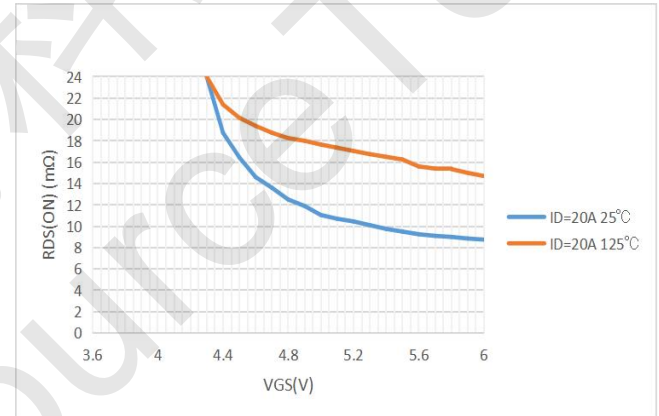

Figure 5: On-Resistance vs. Junction Temperature

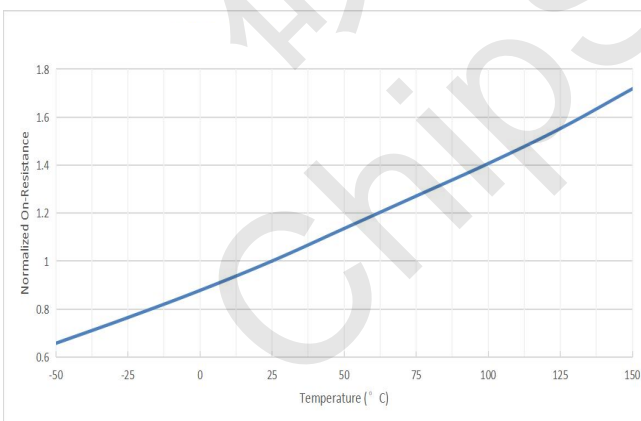
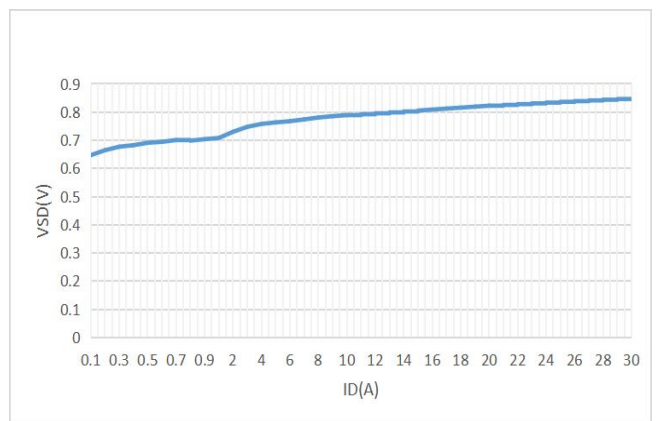

Figure 6: Body-Diode Characteristics





FMB6080G Typical Performance Characteristics

Figure7: Capacitance Characteristics C(pF)

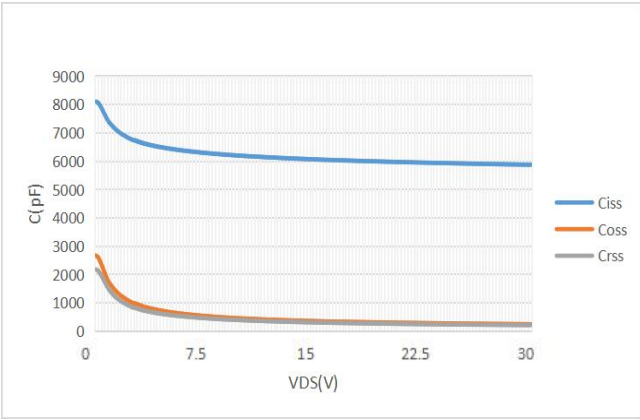

Figure 8: Current De-rating

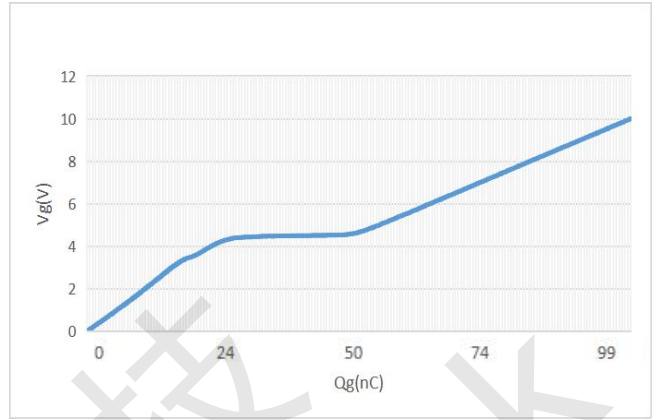

Figure9: Maximum Forward Biased Safe Operating Area

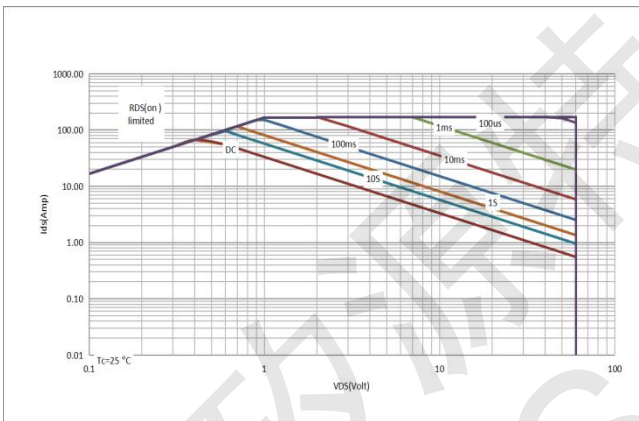
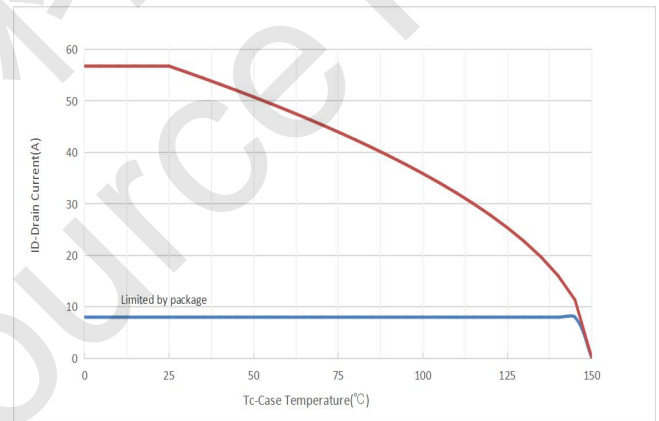

Figure 8: Current De-rating





FMB6080G Test Circuit

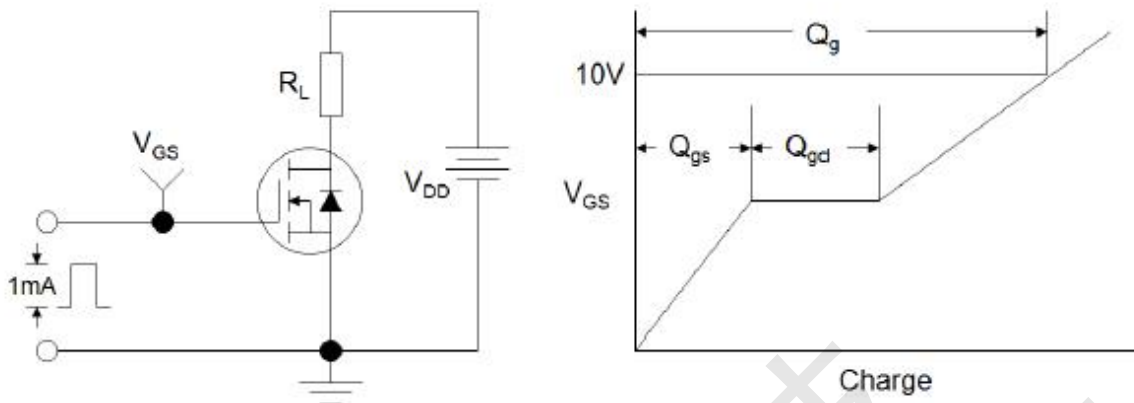

Figure1:Gate Charge Test Circuit & Waveform

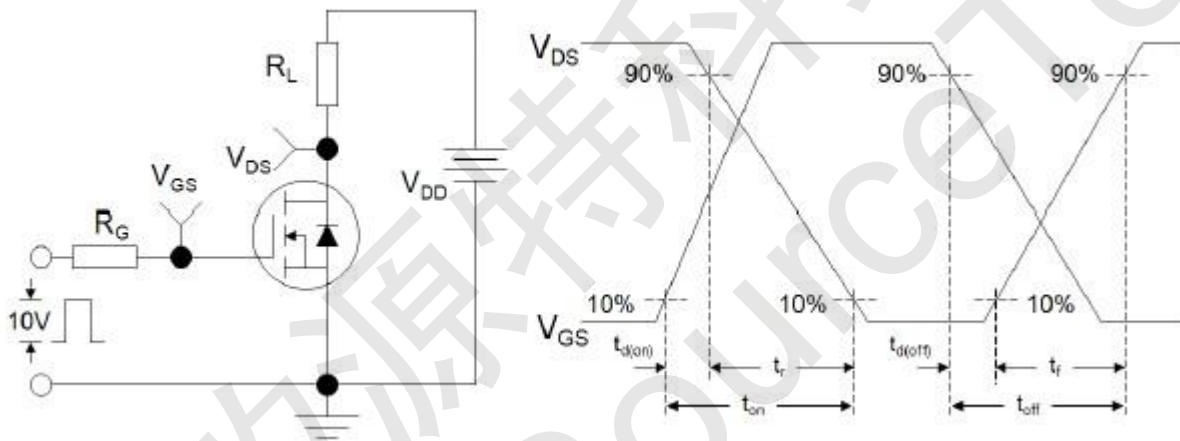

Figure 2: Resistive Switching Test Circuit & Waveforms

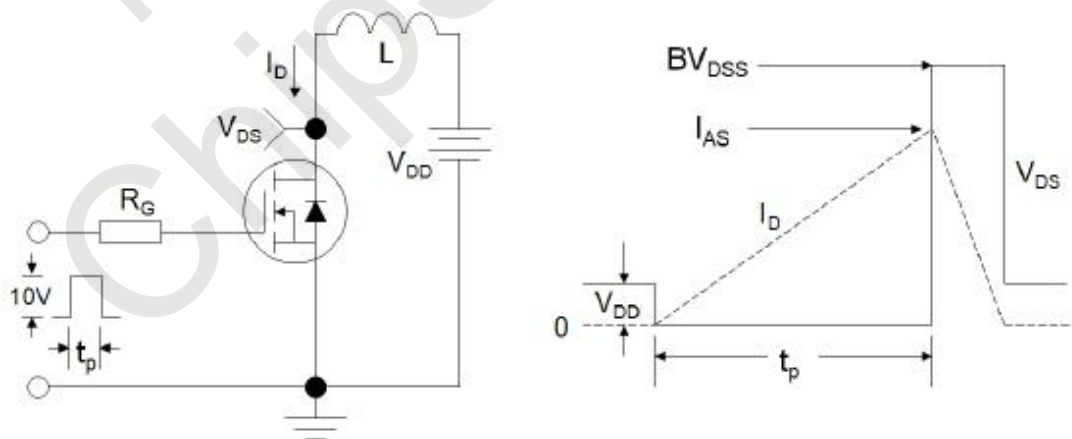

Figure 3:Unclamped Inductive Switching Test Circuit & Waveforms

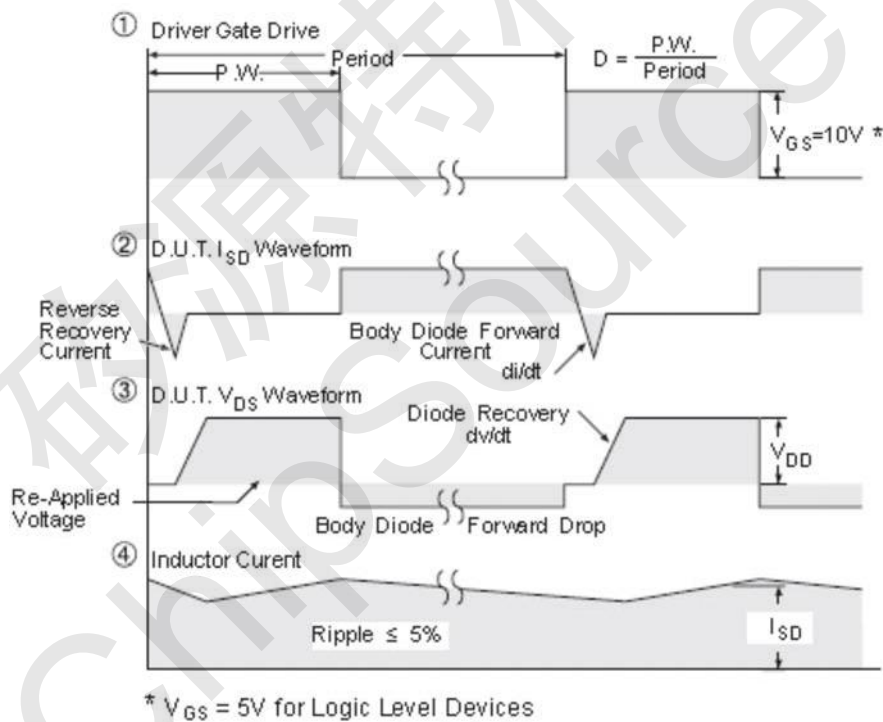
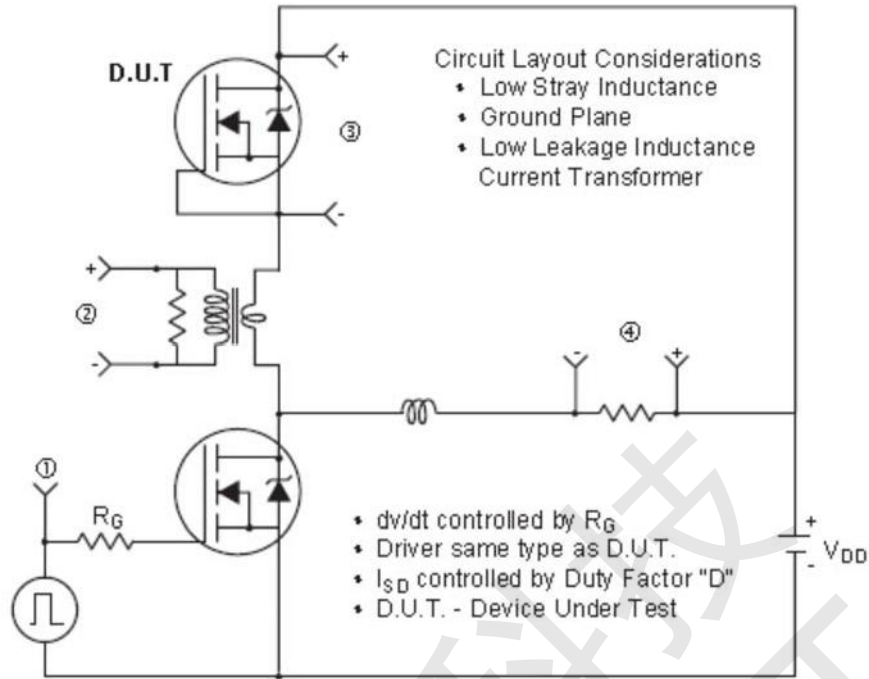
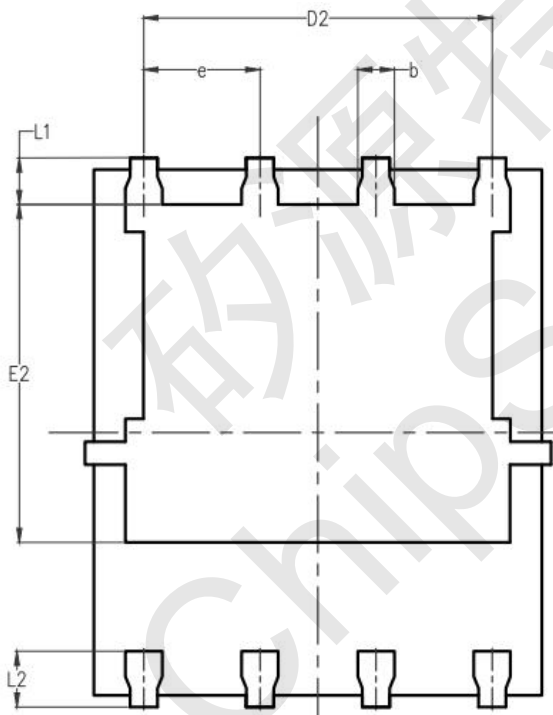
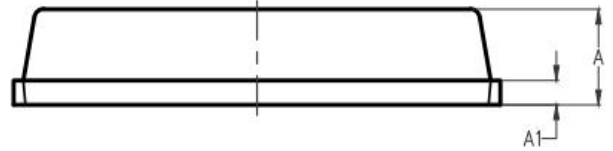
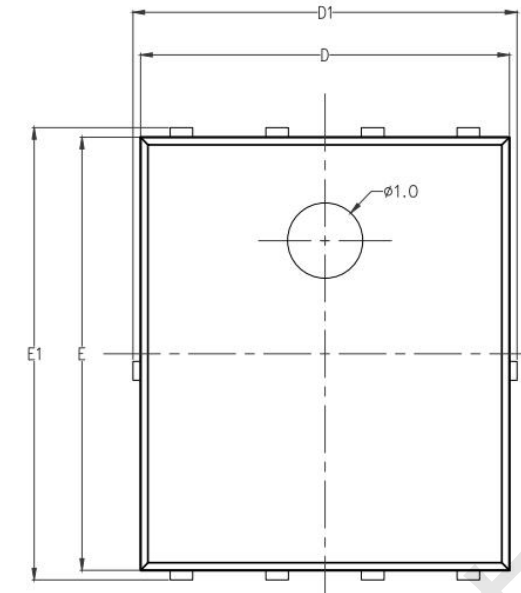

Figure 4: Peak Diode Recovery dv/dt Test Circuit & Waveforms (For N-channel)



FMB6080G PDFN5*6 Package Information



SYMBOL	MILLIMETER		
	MIN	NOM	MAX
A	0.95	1.00	1.05
A1	0.254REF.		
b	0.41	0.46	0.51
D	4.85	4.90	4.95
D1	4.90	5.00	5.10
D2	3.766	3.816	3.866
E	5.696	5.746	5.796
E1	5.95	6.00	6.05
E2	3.525	3.575	3.625
e	1.22	1.27	1.32
L1	0.46	0.51	0.56
L2	0.56	0.61	0.66