



## 100mA Low Power CMOS LDO

### ■ DESCRIPTION

The UP75XX-1 series is a set of three-terminal low power high voltage implemented in CMOS technology. They can deliver 100mA output current and allow an input voltage as high as 30V. They are available with several fixed output voltages ranging from 2.1V to 5.5V. CMOS technology ensure low voltage drop and low quiescent current  
Although designed primarily as fixed voltage regulators, these devices can be used with external components to obtain variable voltages and currents

### ■ FEATURE

- ◆ *Low power consumption*
- ◆ *Low voltage drop*
- ◆ *Low temperature coefficient*
- ◆ *High input voltage 30V*
- ◆ *Quiescent current 2.5uA*
- ◆ *High output current 100mA*
- ◆ *Output voltage accuracy : tolerance 3%*
- ◆ *SOT89, T092, SOT23-5 packages*

### ■ APPLICATIONS

- ◆ Battery-powered equipment
- ◆ Communication equipment
- ◆ Audio/Video equipment

### ■ PIN CONFIGURATION

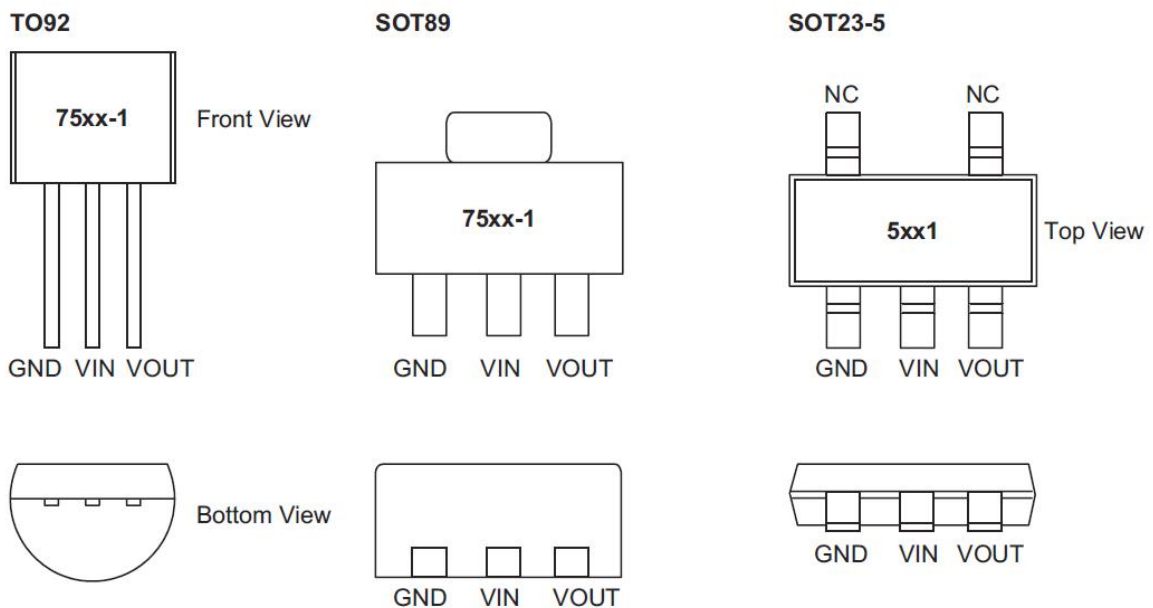



## ■ PART NUMBER INFORMATION

UP75XXA-1-BBC	XX=Voltage A=Package Code S: SOT89 T: TO92 s:SOT23-5L BB=Handing Code TR: Tape&Reel C=Lead Plating Code G: Green Product
---------------	--

## ■ ORDERING INFROMATION

Part Number	Output Voltage	Package	Marking
UP7550S-1-TRG	5.0	SOT89	1000EA / T&R
UP7550T-1-TRG	5.0	TO92	500EA / BAG
UP7550s-1-TRG	5.0	SOT23-5L	3000EA / T&R

## ■ ABSOLUTE MAXIMUM RATINGS ( $T_A = 25^\circ\text{C}$ Unless otherwise noted )

Symbol	Parameter	Typical	Unit
$V_{IN(MAX)}$	Supply Voltage	35	V
$T_J$	Operation Junction Temperature	150	$^\circ\text{C}$
$T_{STG}$	Storage Temperature Range	-55~+150	$^\circ\text{C}$
$T_P$	Operation Temperature	-40~+80	$^\circ\text{C}$

**Note: Absolute maximum ratings are those values beyond which the device could be permanently damaged.  
Absolute maximum ratings are stress rating only and functional device operation is not implied**

## ■ THERMAL DATA

Symbol	Parameter	Package	Max	Unit
$R_{\theta JA}$	Thermal Resistance-Junction to Ambient	SOT23-3L	500	$^\circ\text{C}/\text{W}$
		SOT89	200	$^\circ\text{C}/\text{W}$
		TO92	200	$^\circ\text{C}/\text{W}$
		SOT23-3L	0.2	W



P <sub>D</sub>	Power Dissipation	SOT89	0.5	W
		TO92	0.5	W

■ **ELECTRICAL CHARACTERISTICS**( $T_A=25\text{ }^\circ\text{C}$  Unless otherwise noted)

Symbol	Parameter	Condition	Min	Typ	Max	Unit
V <sub>IN</sub>	Input Voltage				30	V
V <sub>OUT</sub>	Output Voltage	V <sub>IN</sub> =V <sub>OUT</sub> +2V, I <sub>OUT</sub> =10mA	V <sub>OUT</sub> *0.97		V <sub>OUT</sub> *1.03	V
I <sub>OUT</sub>	Output Current	V <sub>IN</sub> =V <sub>OUT</sub> +2V	70	100		mA
ΔV <sub>OUT</sub>	Load Regulation	V <sub>IN</sub> =V <sub>OUT</sub> +2V, 1mA≤I <sub>OUT</sub> ≤50mA		25	60	mV
V <sub>DIF</sub>	Dropout Voltage	I <sub>OUT</sub> =1mA, ΔV <sub>OUT</sub> =2%		30	100	mV
I <sub>SS</sub>	Quiescent Current	No Load		2.2	4.0	uA
ΔV <sub>OUT</sub> /ΔV <sub>IN</sub> *V <sub>OUT</sub>	Line Regulation	V <sub>OUT</sub> +1V≤V <sub>IN</sub> ≤30V, I <sub>OUT</sub> =1mA			0.2	%V

**Note: Dropout voltage is defined as the input voltage minus the output voltage that produces a 2% change in the output voltage from the value at V<sub>IN</sub>=V<sub>OUT</sub>+2V with a fixed load**



## ■ TYPICAL PERFORMANCE CHARACTERISTICS

Test Condition :  $V_{IN}=V_{OUT}+2V$ ,  $I_{OUT}=10mA$ ,  $T_J=25^{\circ}C$ , unless otherwise noted

### Output Voltage vs Input Voltage

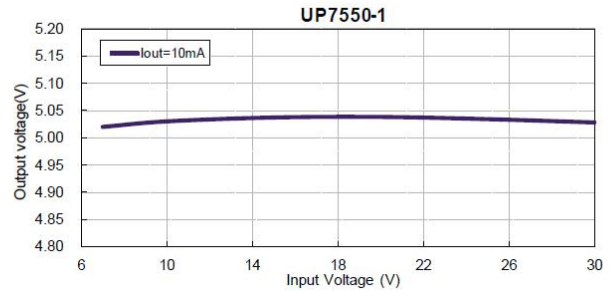
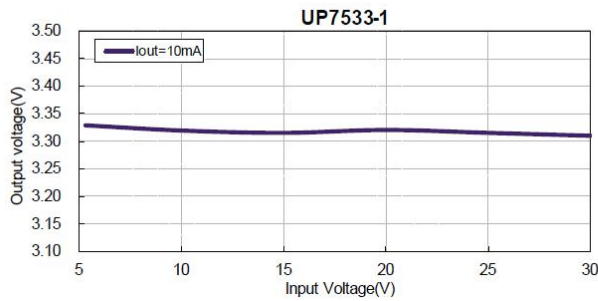

### Output Voltage vs Temperature

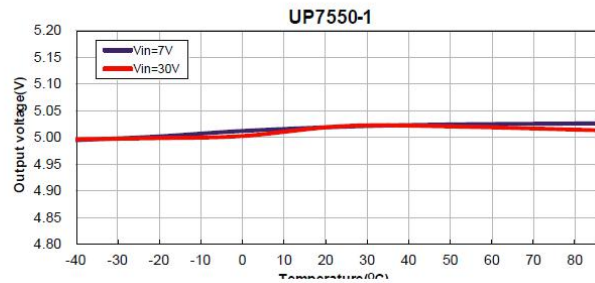
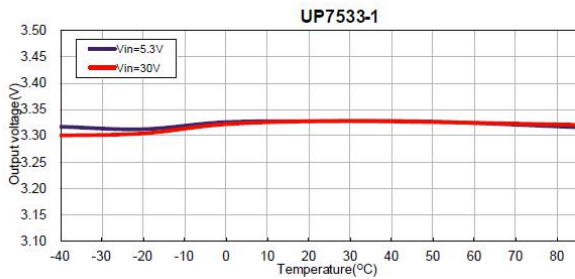

### Output Voltage vs Temperature

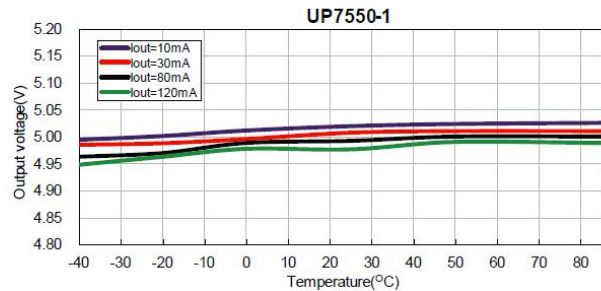
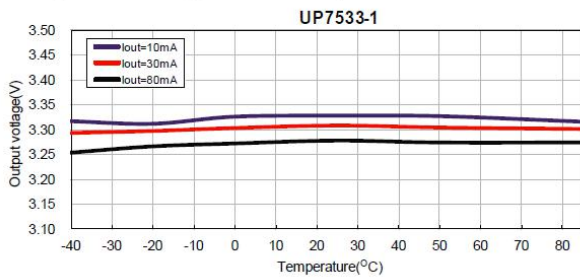



### Quiescent current (I<sub>out</sub>=0mA) vs Temperature

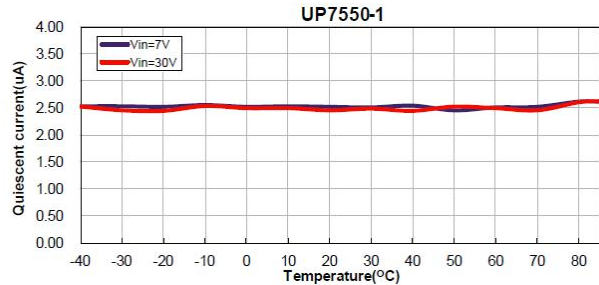
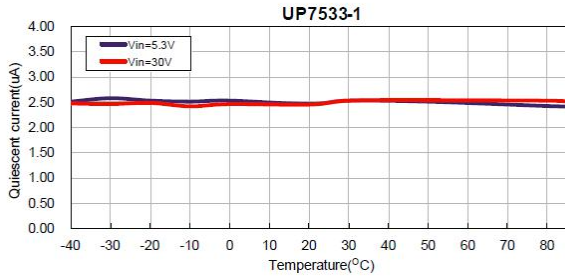

## APPLICATION CIRCUITS

### Basic Circuit

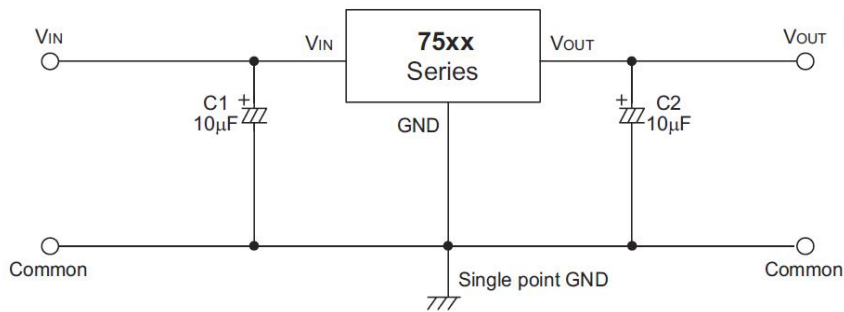

### High Output Current Positive Voltage Regulator

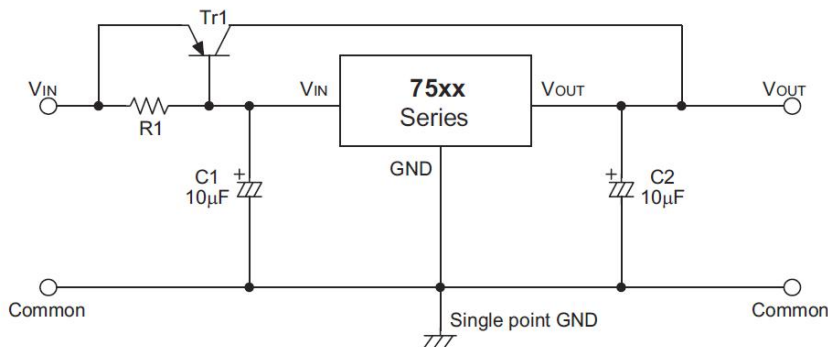



### Short-Circuit Protection for Tr1

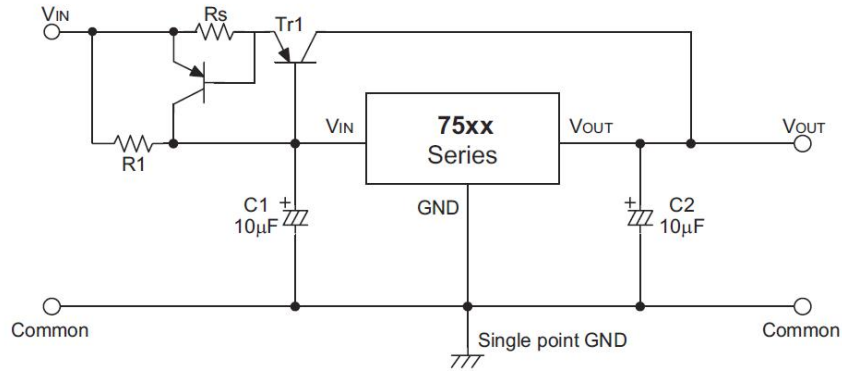

## ■ SOLDERING METHODS FOR UNIVERCHIP

Storage environment Temperature=10°C~35°C Humidity=65%±15%

Reflow soldering of surface mount device

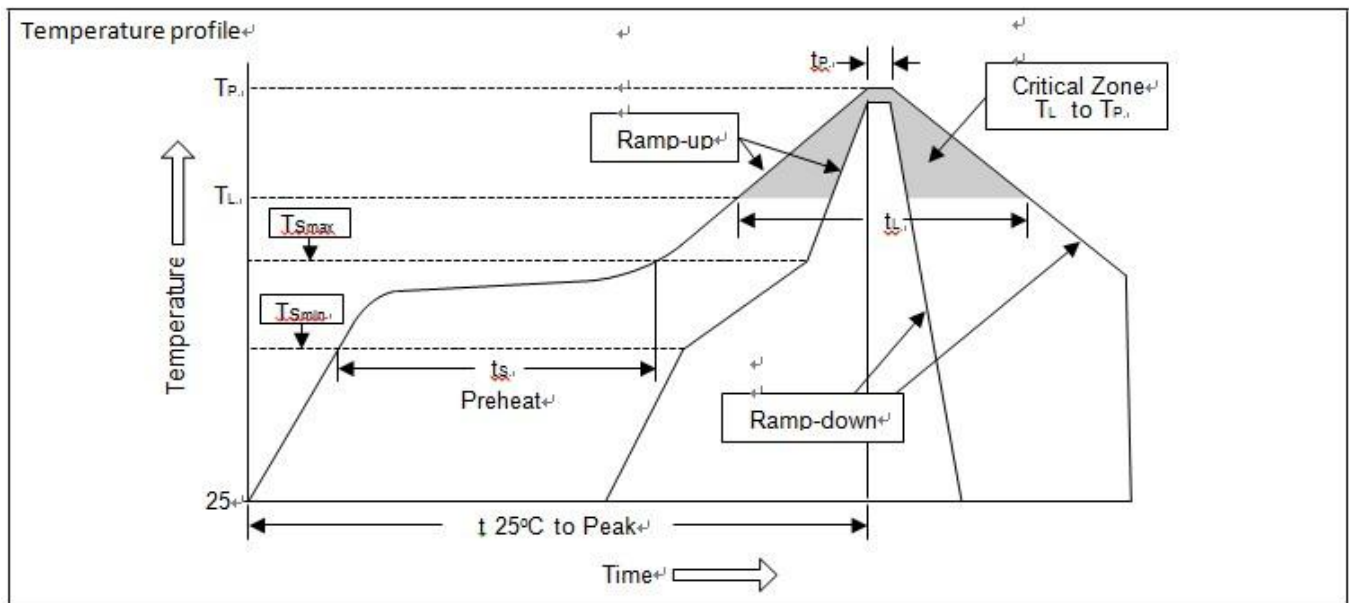

TEL: +86-0755-27595155 27595165 29359583 29359586

FAX: +86-0755-27594792

WEB: [Http://www.ChipSourceTek.com](http://www.ChipSourceTek.com)

E-mail: [Tony.Wang@ChipSourceTek.com](mailto:Tony.Wang@ChipSourceTek.com)

InFo@ChipSourceTek.com





Profile Feature	Sn-Pb Eutectic Assembly	Pb free Assembly
Average ramp-up rate ( $T_L$ to $T_P$ )	<3°C/sec	<3°C/sec
Preheat		
-Temperature Min ( $T_{Smin}$ )	100°C	150°C
-Temperature Max ( $T_{Smax}$ )	150°C	200°C
-Time (min to max) (ts)	60~120 sec	60~180 sec
$T_{Smax}$ to $T_L$		
-Ramp-up Rate	<3°C/sec	<3°C/sec
Time maintained above		
-Temperature ( $T_L$ )	183°C	217°C
-Time ( $t_L$ )	60~150 sec	60~150 sec
Peak Temperature ( $T_P$ )	240°C+0/-5°C	260°C+0/-5°C
Time within 5°C of actual Peak Temperature ( $t_P$ )	10~30 sec	20~40 sec
Ramp-down Rate	<6°C/sec	<6°C/sec
Time 25°C to Peak Temperature	<6 minutes	<6 minutes

Flow (wave) soldering (solder dipping)

Product	Peak Temperature	Dipping Time
Pb device	245°C±5°C	5sec±1sec
Pb-Free device	260°C+0/-5°C	5sec±1sec



This integrated circuit can be damaged by ESD. UniverChip Corporation recommends that all integrated circuits be handled with appropriate precautions. Failure to observe proper handling and installation procedure can cause damage. ESD damage can range from subtle performance degradation to complete device failure. Precision integrated circuits may be more susceptible to damage because very small parametric changes could cause the device not to meet its published specifications.