



## 1.3A Lithium Ion, 9V Input Voltage Battery Linear Charger ME4057-N Series

### General Description

ME4057-N is a complete constant-current/constant voltage linear charger for single cell lithium-ion batteries. With a thermally enhanced 8-PIN SOP package on the bottom and low external component count make the ME4057-N ideally suited for portable applications. Furthermore the ME4057-N is specifically designed to work within USB power specifications.

No external sense resistor is needed and no blocking diode is required due to the internal PMOSFET architecture. Thermal feedback regulates the charge current to limit the die temperature during high power operation or high ambient temperature. The charge voltage is fixed at 4.2V/4.34V/4.4V, and the charge current can be programmed externally with a single resistor. The ME4057-N automatically terminates the charge cycle when the charge current drops to 1/10<sup>th</sup> the programmed value after the final float voltage is reached.

When the input supply (wall adapter or USB supply) is removed the ME4057-N automatically enters a low current state dropping the battery drain current to less than 2 $\mu$ A. The ME4057-N can be put into shutdown mode reducing the supply current to 55 $\mu$ A.

Other features include Battery temperature monitor, under-voltage lockout, automatic recharge and two status pins to indicate charge and charge termination.

### Typical Applications

- Cellular Telephones, Digital Still Cameras
- MP3 Players
- Bluetooth Applications
- Portable Devices
- USB Bus-Powered Chargers

### Features

- Protection of battery cell reverse connection
- Maximum operating voltage 9V, improve system reliability
- Programmable charge current up to: 1.3A (ESOP8) ; 1 A (DFN2\*2-8L)
- Internal thermal feedback protection control system in reasonable charge range
- No MOSFET sense resistor or blocking diode required
- Complete linear Charger in ESOP8 Package for single Cell Lithium-Ion Batteries.
- Constant-Current/Constant-Voltage operation with thermal regulation to maximize Rate Without risk of overheating.
- Preset 4.2V/4.34V/4.4V charge voltage with  $\pm 1\%$  accuracy
- Automatic Recharge
- Two Status Indication for Charge status, no battery and battery failure indicators
- C/10 charge termination
- 55 $\mu$ A supply current in shutdown
- 2.9V trickle current charge threshold
- Soft-Start limits inrush current
- Battery Temperature Sensing

### Package

- 8-pin ESOP8, DFN2\*2-8



### Typical charge cycle (1000mAh battery)

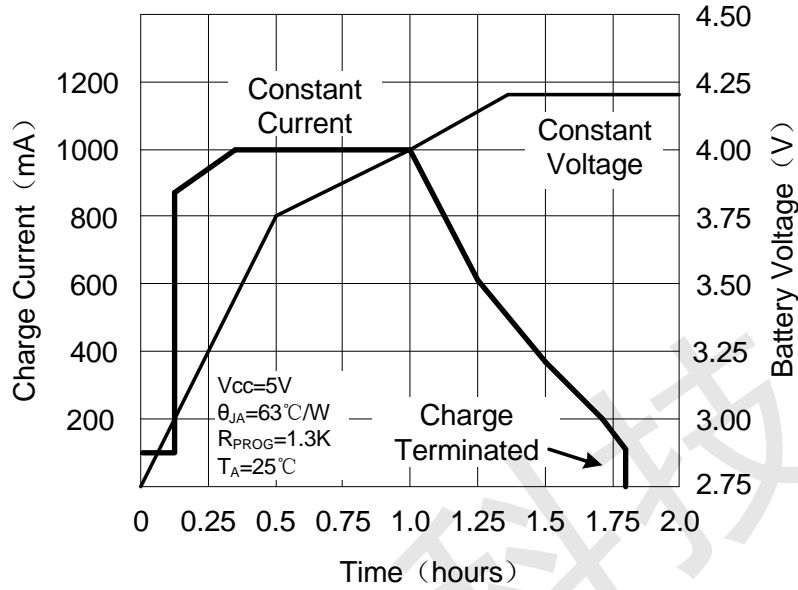

### Selection Guide

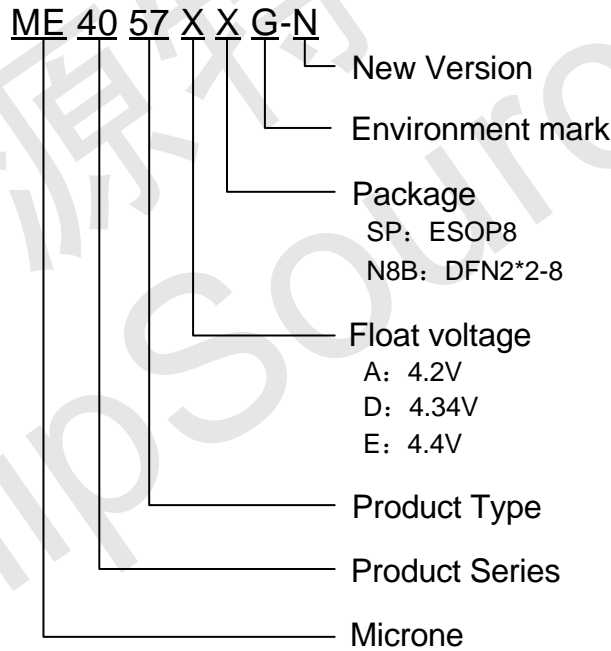

product series	product description
ME4057ASPG-N	$V_{\text{FLOAT}} = 4.2\text{V}$ , $\text{IBAT}_{\text{MAX}} = 1.3\text{A}$ , Package: ESOP8
ME4057ASPG-NA	$V_{\text{FLOAT}} = 4.2\text{V}$ , $\text{IBAT}_{\text{MAX}} = 1.3\text{A}$ , Package: ESOP8, Constant current accuracy: $\pm 5\%$
ME4057AN8BG-N	$V_{\text{FLOAT}} = 4.2\text{V}$ , $\text{IBAT}_{\text{MAX}} = 1\text{A}$ , Package: DFN2*2-8
ME4057DSPG-N	$V_{\text{FLOAT}} = 4.34\text{V}$ , $\text{IBAT}_{\text{MAX}} = 1.3\text{A}$ , Package: ESOP8
ME4057ESPG-N	$V_{\text{FLOAT}} = 4.4\text{V}$ , $\text{IBAT}_{\text{MAX}} = 1.3\text{A}$ , Package: ESOP8

**NOTE:** If you need other voltage and package, please contact our sales staff.



## Pin Configuration

ME4057-N

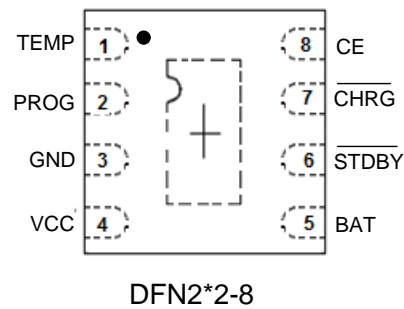
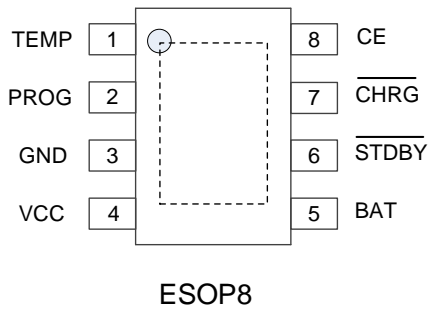

## Pin Assignment

Pin Num.	Symbol	Function
1	TEMP	<b>Temperature sense input</b> Connecting TEMP pin to NTC thermistor's output in Lithium ion battery pack. If TEMP pin's voltage is below 45% or above 80% of supply voltage VCC, this means that battery's temperature is too low or too high, charging is suspended. The temperature sense function can be disabled by grounding the TEMP pin.
2	PROG	<b>Constant Charge Current Setting and Charge Current Monitor Pin</b> The charge current is programmed by connecting a resistor $R_{PROG}$ from this pin to GND. When in precharge mode, the PROG pin's voltage is regulated to 0.1V. When charging in constant-current mode this pin's voltage is regulated to 1V. In all modes during charging, the voltage on this pin can be used to measure the charge current using the following formula: $I_{BAT} = \frac{V_{PROG}}{R_{PROG}} * 1300$
3	GND	<b>Ground</b>
4	VCC	<b>Positive input supply voltage</b> Provides power to the internal circuit. When VCC drops to within 80mV of the BAT pin voltage, the ME4057-N enters low power sleep mode, dropping $I_{BAT}$ to less than 2 $\mu$ A.
5	BAT	<b>Battery connection Pin</b> Connect the positive terminal of the battery to this pin. Dropping BAT pin's current to less than 2 $\mu$ A when IC in disable mode or in sleep mode. BAT pin provides charge current to the battery and provides regulation voltage of 4.2V /4.34V/4.4V.
6	_____	<b>Charge terminated status output</b> _____ is pulled low by an internal switch to indicate a battery charge terminated; this means Charge termination. Otherwise _____ pin is in high impedance state.
7	_____	<b>Open-Drain charge status output</b> When the battery is being charged, the _____ pin is pulled low by an internal switch, otherwise, _____ pin is in high impedance state.
8	CE	<b>Chip enable input</b> A high input will put the device in the normal operating mode. Pulling the CE pin to low level will put the ME4057-N into disable mode. The CE pin can be driven by TTL or CMOS logic level.



Block Diagram

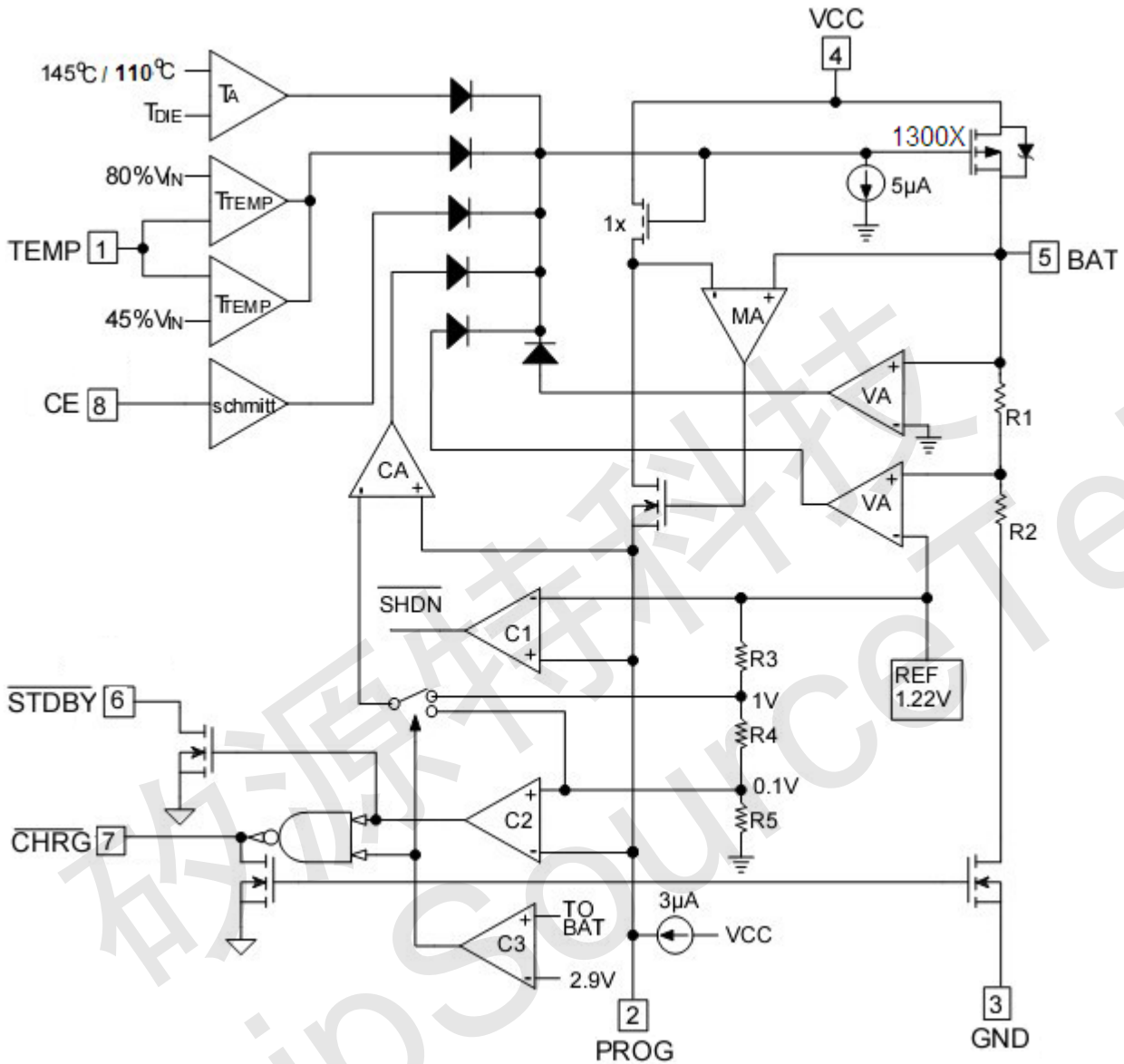



**Absolute Maximum Ratings**

Parameter		Rating	Unit
Input supply voltage : VCC		-0.3~10	V
PROG pin voltage		-0.3~VCC+0.3	V
BAT pin voltage		-0.3~10	V
TEMP pin voltage		-0.3~10	V
_____ pin voltage		-0.3~10	V
_____ pin voltage		-0.3~10	V
CE pin voltage		-0.3~10	V
BAT pin current		1500	mA
PROG pin current		1200	μA
Maximum Power Dissipation: Pd	ESOP8	1500	mW
	DFN2*2-8	1000	mW
Package thermal impedance $\theta_{JA}$	ESOP8	63	°C/W
	DFN2*2-8	98	
Maximum junction temperature		-40~150	°C
Operating ambient temperature : $T_{opa}$		-40~85	°C
Storage temperature : $T_{str}$		-55~150	°C
Soldering temperature and time		+260 (Recommended 10S)	°C

Caution: The absolute maximum ratings are rated values exceeding which the product could suffer physical damage. These values must therefore not be exceeded under any conditions.

**Electrical Characteristics**

Symbol	Parameter	Condition	Min	Typ.	Max	Unit	
VCC	Input supply voltage	•	4.0	5.0	9.0	V	
I <sub>CC</sub> -I <sub>BAT</sub>	static current	•Charge mode, R <sub>PROG</sub> =1KΩ	-	150	500	μA	
		•Standby mode(charge end)	-	55	100	μA	
		•Shutdown mode (R <sub>PROG</sub> not connected, VCC<V <sub>BAT</sub> , or VCC<V <sub>UV</sub> )	-	55	100	μA	
V <sub>FLOAL</sub>	Regulated output voltage	0°C≤T <sub>A</sub> ≤85°C	ME4057A-N	4.158	4.2	4.242	V
			ME4057D-N	4.296	4.34	4.383	
			ME4057E-N	4.356	4.4	4.444	
I <sub>BAT</sub>	BAT pin current (The condition of current mode is V <sub>BAT</sub> =3.9V)	•R <sub>PROG</sub> =2KΩ, current mode	ME4057ASPG-NA	618	650	683	mA
			Others	550	650	700	mA
		•R <sub>PROG</sub> =1KΩ, current mode	ME4057ASPG-NA	1235	1300	1365	mA
			Others	1100	1300	1400	mA
		•Standby mode	V <sub>BAT</sub> =4.2V/4.34V/4.4V	-6	-2.5	0	μA
		Shutdown mode, R <sub>PROG</sub> not connected		-	±1	±2	μA
Sleep mode, V <sub>CC</sub> =0V		-	-1	-2	μA		



ME4057-N						
$I_{TRIKL}$	Trickle charge current	• $V_{BAT} < V_{TRIKL}$ , $R_{PROG} = 10K\Omega$	10	19	36	mA
$V_{TRIKL}$	Trickle charge threshold voltage	$R_{PROG} = 1K\Omega$ , $V_{BAT}$ rising	2.7	2.85	3.0	V
$V_{TRHYS}$	Trickle voltage hysteresis voltage	$R_{PROG} = 1K\Omega$	350	400	450	mV
$V_{UV}$	$V_{CC}$ under voltage lockout threshold	• VCC from low to high	3.5	3.7	3.9	V
$V_{UVHYS}$	$V_{CC}$ under voltage lockout hysteresis	•	150	200	300	mV
$V_{ASD}$	$V_{CC} - V_{BAT}$ lockout threshold voltage	VCC from low to high	100	140	180	mV
		VCC from high to low	50	80	110	
$I_{TERM}$	C/10 termination current threshold	• $R_{PROG} = 2K\Omega$		70		mA
		• $R_{PROG} = 1K\Omega$		130		
$V_{PROG}$	PROG pin voltage	• $R_{PROG} = 1K\Omega$ , current mode	0.9	1.0	1.1	V
$V_{CHRG}$	$\overline{CHRG}$ Pin output low voltage	$I_{CHRG} = 5mA$	-	0.3	0.6	V
$V_{STDBY}$	$\overline{STDBY}$ Pin output low voltage	$I_{STDBY} = 5mA$	-	0.3	0.6	V
$V_{TEMP-H}$	The voltage at TEMP increase		-	80	83	% $V_{CC}$
$V_{TEMP-L}$	The voltage at TEMP decrease		42	45	-	% $V_{CC}$
$\Delta V_{RECHRG}$	Recharge battery threshold voltage	$V_{FLOAT} - V_{RECHRG}$	60	150	240	mV
$T_{LIM}$	Thermal protection temperature		-	145	-	°C
$R_{ON}$	The resistance of power FET "ON" (between $V_{CC}$ and BAT)		-	650	-	mΩ
$t_{SS}$	Soft-start time	$I_{BAT} = 0$ to $I_{BAT} = 1300V/R_{PROG}$	-	20	-	μS
$t_{RECHARGE}$	Recharge comparator filter time	$V_{BAT}$ from low to high	0.8	1.8	4	mS
$t_{TERM}$	Termination comparator filter time	$I_{BAT}$ below $I_{CHG}/10$	0.8	1.8	4	mS
$I_{PROG}$	PROG pin pull-up current		-	2.0	-	μA

**Note:** The • denotes specifications which apply over the full operating temperature rang, otherwise specifications are at  $T_A = 25^\circ C$ ,  $V_{CC} = 5V$ , unless otherwise specified.



Typical performance characteristics

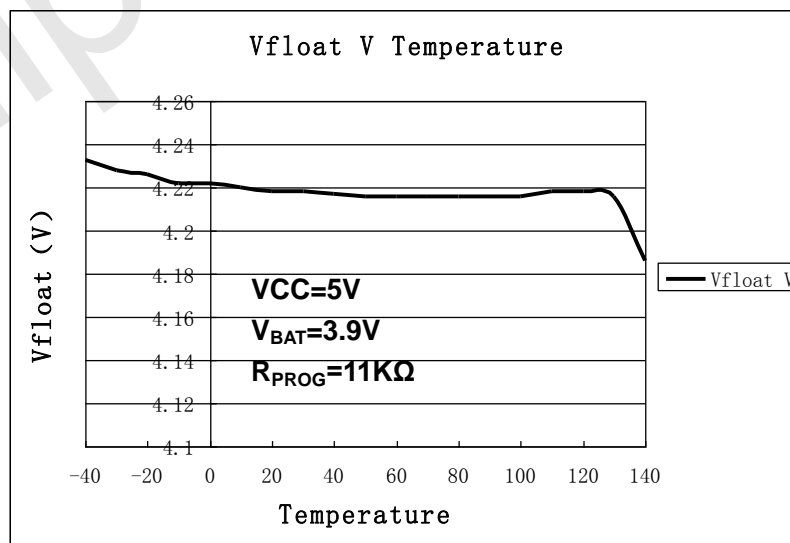
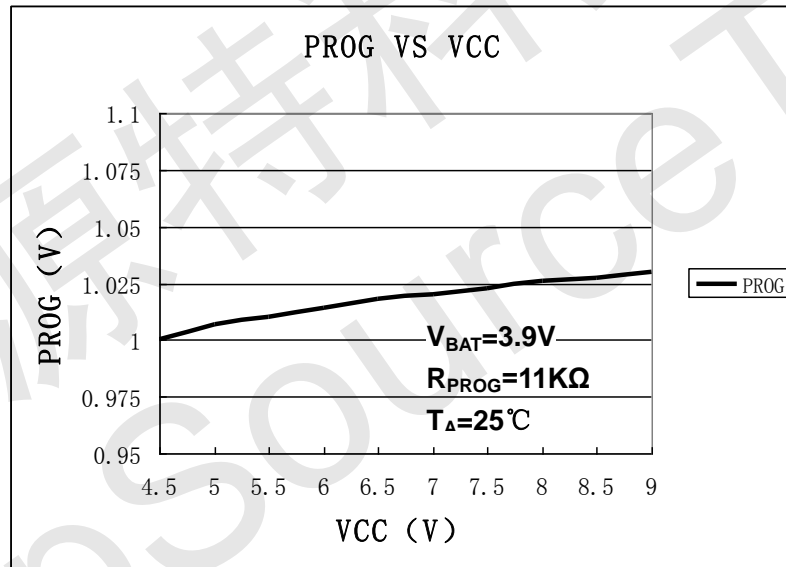
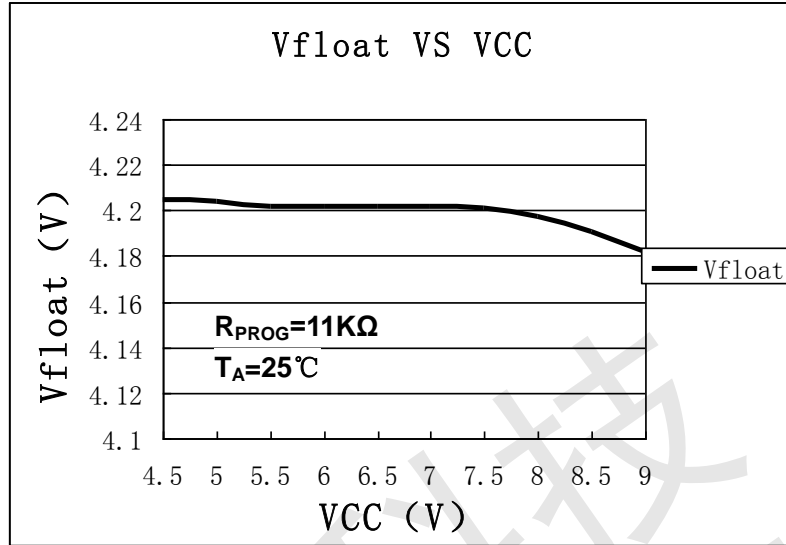

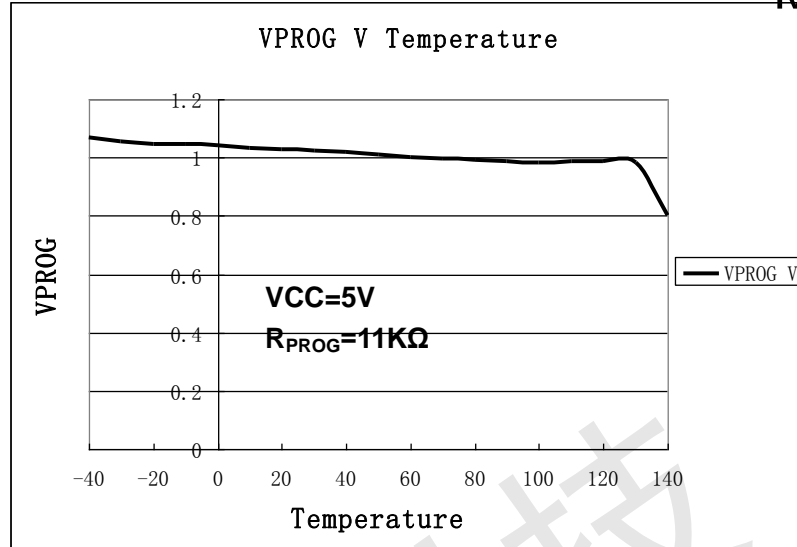

## Description of the Principle

The ME4057-N is a complete constant-current/constant-voltage linear charger for single cell lithium-ion batteries. Constant-current/constant-voltage to charger batter by internal MOSFET. It can deliver up to 1.3A of charge current. No blocking diode or external current sense resistor is required. ME4057-N include two Open-Drain charge status Pins: Charge status indicator  $\overline{\text{CHRG}}$  and battery failure status output  $\overline{\text{STDBY}}$ .

The internal thermal regulation circuit reduces the programmed charge current if the die temperature attempts to rise above a preset value of approximately 145°C. This feature protects the ME4057-N from excessive temperature, and allows the user to push the limits of the power handling capability of a given circuit board without risk of damaging the ME4057-N or the external components. Another benefit of adopting thermal regulation is that charge current can be set according to typical, not worst-case, ambient temperatures for a given application with the assurance that the charger will automatically reduce the current in worst-case conditions.

The charge cycle begins when the voltage at the VCC pin rises above the UVLO level, a current set resistor is connected from the PROG pin to ground, and the CE pin is pulled above the chip enable threshold. The  $\overline{\text{CHRG}}$  pin outputs a logic low to indicate that the charge cycle is on going. At the beginning of the charge cycle, if the battery voltage is below 2.9V, the charge is in precharge mode to bring the cell voltage up to a safe level for charging. The charger goes into the fast charge constant-current mode once the voltage on the BAT pin rises above 2.9 V. In constant current mode, the charge current is set by  $R_{\text{PROG}}$ . When the battery approaches the regulation voltage 4.2V/4.34V/4.4V, the charge current begins to decrease as the ME4057-N enters the constant-voltage mode. When the current drops to charge termination threshold, the charge cycle is terminated, and  $\overline{\text{CHRG}}$  pin assumes a high impedance state to indicate that the charge cycle is terminated and  $\overline{\text{STDBY}}$  pin is pulled low. The charge





termination threshold is 10% of the current in constant current mode. To restart the charge cycle, remove the input voltage and reapply it, or momentarily force CE pin to 0V. The charge cycle can also be automatically restarted if the BAT pin voltage falls below the recharge threshold. The on-chip reference voltage, error amplifier and the resistor divider provide regulation voltage with 1% accuracy which can meet the requirement of lithium-ion and lithium polymer batteries.

When the input voltage is not present, or input voltage is below  $V_{BAT}$ , the charger goes into a sleep mode, dropping battery drain current to less than  $3\mu A$ . This greatly reduces the current drain on the battery and increases the standby time. The charger can be shutdown by forcing the CE pin to GND.

The charging profile is shown in the following figure:

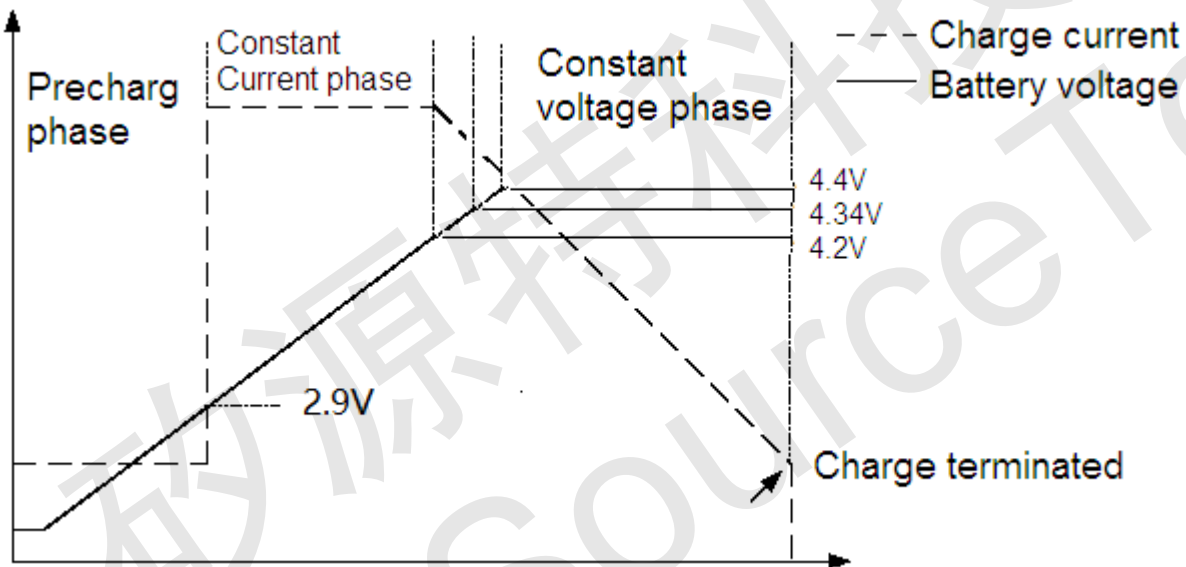

### Programming charge current

The charge current is set using a resistor connected between the PROG pin and ground. The formula for setting the resistor and charging current is as follows:

$$R_{PROG} = 1300 / I_{BAT}$$

### Charge termination

A charge cycle is terminated when the charge current falls to 1/10th the programmed value after the final float voltage is reached. This condition is detected by using an internal filtered comparator to monitor the PROG pin. When the PROG pin voltage falls below 100mV for longer than  $t_{TEMP}$  (typically 1.8mS), Charging is terminated. The charge current is latched off and the ME4057-N enters standby mode, where the input supply current drops to  $55\mu A$  (Note: C/10 termination is disabled in trickle charging and thermal limiting modes).

When charging, transient loads on the BAT pin can cause the PROG pin to fall below 100mV for short periods of time before the DC charge current has dropped to 1/10th the programmed value. The 1.8mS filter time ( $t_{TEMP}$ ) on



## ME4057-N

the termination comparator ensures that transient loads of this nature do not result in premature charge cycle termination. Once the average charge current drops below 1/10th the programmed value, the ME4057-N terminated the charge cycle and ceases to provide any current through the BAT pin. In this state all loads on the BAT pin must be supplied by the battery.

The ME4057-N constantly monitors the BAT pin voltage in standby mode. If this voltage drops below the 4.02V recharge threshold, another charge cycle begins and current is once again supplied to the battery. To manually restart a charge cycle when in standby mode, the input voltage must be removed and reapplied or the charger must be shut down and restarted using the PROG pin. Figure 1 shows the state diagram of a typical charge cycle.

### Charge status indicator

ME4057-N has two open-drain status indicator output  $\overline{\text{CHRG}}$  and  $\overline{\text{STDBY}}$ .  $\overline{\text{CHRG}}$  is pull-down when the ME4057-N in a charge cycle. In other status  $\overline{\text{CHRG}}$  in high impedance.  $\overline{\text{CHRG}}$  and  $\overline{\text{STDBY}}$  are all in high impedance when the battery out of the normal temperature.

Represent in failure state, when TEMP pin in typical connecting, or the charger with no battery: red LED and green LED all don't light. The battery temperature sense function is disabled by connecting TEMP pin to GND. If battery is not connected to charger,  $\overline{\text{CHRG}}$  pin outputs a PWM level to indicate no battery. If BAT pin connects a 10 $\mu$ F capacitor, the frequency of  $\overline{\text{CHRG}}$  flicker about 1-4S, If not use status indicator should set status indicator output connected to GND.

charger's status	Red led $\overline{\text{CHRG}}$	Green led $\overline{\text{STDBY}}$
Charging	light	dark
Battery in full state	dark	light
Under-voltage, battery's temperature is to high or too low, or not connect to battery(use TEMP)	dark	dark
BAT pin is connected to 10 $\mu$ F capacitor, No battery mode (TEMP=GND)	Green LED bright, Red LED flicker F=1-4 S (At this time, reverse-battery, the light does not shine, this phenomenon is normal. Such a case, after the battery is properly connected to the indicator light back to light and flicker.)	

### Thermal limiting

An internal thermal feedback loop reduces the programmed charge current if the die temperature attempts to rise above a preset value of approximately 140 $^{\circ}$ C. The feature protects the ME4057-N from excessive temperature and allows the user to push the limits of the power handling capability of a given circuit board without risk of damaging the ME4057-N. The charge current can be set according to typical (not worst-case) ambient temperature with the assurance that the charger will automatically reduce the current in worst-case conditions.

To prevent the damage caused by the very high or very low temperature done to the battery pack, the



## ME4057-N

ME4057-N continuously senses battery pack temperature by measuring the voltage at TEMP pin determined by the voltage divider circuit and the battery's internal NTC thermistor as shown in Figure 1.

The ME4057-N compares the voltage at TEMP pin (VTEMP) against its internal VLOW and VHIGH thresholds to determine if charging is allowed. In ME4057-N, VLOW is fixed at (45%×VCC), while VHIGH is fixed at (80%×VCC). If VTEMP<VLOW or VTEMP>VHIGH, it indicates that the battery temperature is too high or too low and the charge cycle is suspended. When VTEMP is between VLOW and VHIGH, charge cycle resumes. The battery temperature sense function can be disabled by connecting TEMP pin to GND.

### Selecting R1 and R2

The values of R1 and R2 in the application circuit can be determined according to the assumed temperature monitor range and thermistor's values. The Follows is an example: Assume temperature monitor range is TL~TH, ( TL<TH); the thermistor in battery has negative temperature coefficient (NTC, RTL is thermistor's resistance at TL, RTH is the resistance at TH, so RTL>RTH, then at temperature TL, the voltage at TEMP pin is:

$$V_{TEMPH} = \frac{R2//R_{TH}}{R1 + R2//R_{TH}} \times VIN$$

At temperature TH, the voltage at TEMP pin is:

$$V_{TEMPL} = \frac{R2//R_{TL}}{R1 + R2//R_{TL}} \times VIN$$

We know VTEMPL=VHIGH=K2×VCC (K2=0.8); VTEMPH=VLOW=K1×VCC (K1=0.45) Then we can have:

$$R1 = \frac{R_{TL} \times R_{TH} (K2 - K1)}{(R_{TL} - R_{TH}) K1 \times K2} \quad R2 = \frac{R_{TL} \times R_{TH} (K2 - K1)}{R_{TL} (K1 - K1 \times K2) - R_{TH} (K2 - K1 \times K2)}$$

For example, NCP03YS110, operating Temperature is -40°C to 125°C. If using environment temperature is -25°C to 125°C, then RTL is the value of the resistance of NCP03YS110 at -25°C, about 66.148Ω; RTH= is the value of the resistance of NCP03YS110 at 125°C, about 1.077Ω.

Likewise, for positive temperature coefficient thermistor in battery, we have RTH>RTL and we can calculate:

$$R1 = \frac{R_{TL} \times R_{TH} (K2 - K1)}{(R_{TH} - R_{TL}) K1 \times K2} \quad R2 = \frac{R_{TL} \times R_{TH} (K2 - K1)}{R_{TH} (K1 - K1 \times K2) - R_{TL} (K2 - K1 \times K2)}$$

We can conclude that temperature monitor range is independent of power supply voltage VCC and it only depends on R1, R2, RTL and RTH: The values of RTH and RTL can be found in related battery handbook or deduced from testing data. In actual application, if only one terminal temperature is concerned (normally protecting overheating), there is no need to use R2 but R1. It becomes very simple to calculate R1 in this case.



## Under Voltage lockout (UVLO)

ME4057-N

An internal under voltage lockout circuit monitors the input voltage and keeps the charger in shutdown mode until VCC rises above the under voltage lockout threshold . If the UVLO comparator is tripped, the charger will not come out of shutdown mode until VCC rises 140mV above the battery voltage.

## Manual terminate

At any time of the cycle of charging will put the ME4057-N into disable mode to pull CE pin to GND, or remove RPROG ( PROG pin is float) . This made the battery drain current to less than 2μA and reducing the supply current to 55μA. To restart the charge cycle, set CE pin in high level or connect a programming resistor.

If ME4057-N in the under voltage Lockout mode, the \_\_\_\_\_ and \_\_\_\_\_ are all in high impedance state, or VCC is above BAT pin 140mV, or VCC is too low.

## Auto restart

Once charge is been terminated, ME4057-N immediately use a 1.8ms filter time ( tRECHARGE ) on the termination comparator to constant monitor the voltage on BAT pin. If this voltage drops below the 4.02V recharge threshold (about between 80% and 90% of VCC), another charge cycle begins. This ensured the battery maintained (or approach) to a charge full status and avoid the requirement of restarting the periodic charging cycle. In the recharge cycle, \_\_\_\_\_ pin enters a pulled down status.

## Stability Considerations

In constant-current mode, the PROG pin is in the feedback loop, not the battery. The constant-current mode stability is affected by the impedance at the PROG pin. With no additional capacitance on the PROG pin, the charger is stable with program resistor values as high as 20KΩ. However, additional capacitance on this node reduces the maximum allowed program resistor. Therefore, if IPROG pin is loaded with a capacitance C, the following equation should be used to calculate the maximum resistance value for RPROG:

$$R_{\text{PROG}} \leq \frac{1}{2\pi \times 10^5 \times C_{\text{PROG}}}$$

As user, may think charge current is important, not instantaneous current. For example, to run a low current mode switch power which parallel connected with battery, the average current from BAT pin usually importance to instantaneous current. In this case, In order to measure average charge current or isolate capacitive load from IPROG pin, a simple RC filter can be used on PROG pin as shown in Figure 2. In order to ensure the stability add a 10KΩ resistor between PROG pin and filter capacitor.

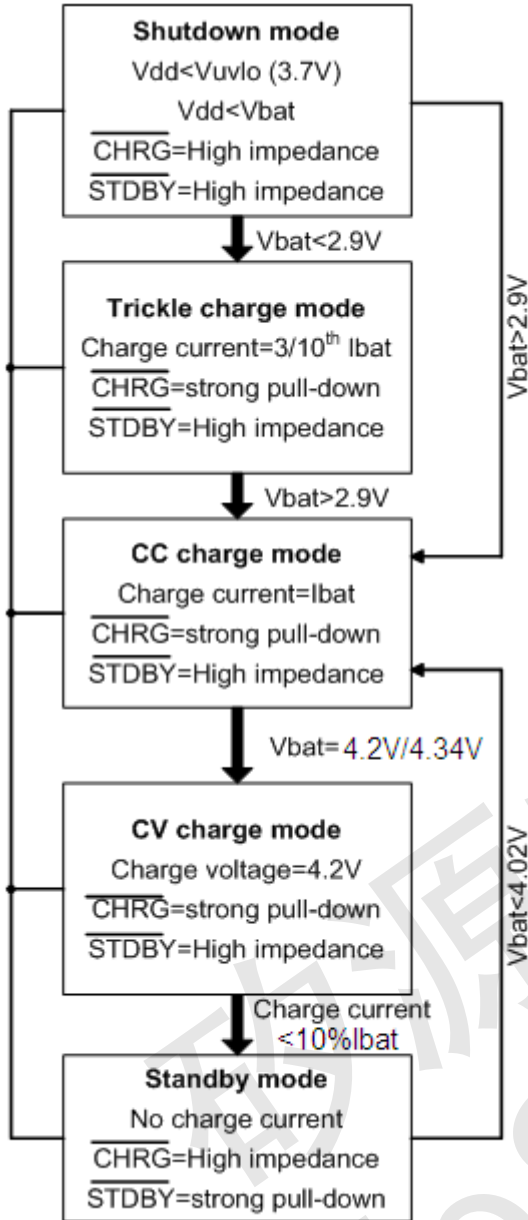

Fig.1 State diagram of a typical charge cycle

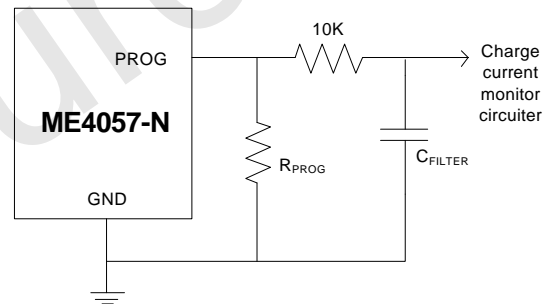

Fig.2 Isolating with capacitive load on PROG Pin

### Power dissipation

The conditions that cause the ME4057-N to reduce charge current through thermal feedback can be approximated by considering the power dissipated in the IC. Nearly all of this power dissipation is generated by the internal MOSFET-this is calculated to be approximately:

$$P_D = (V_{CC} - V_{BAT}) \times I_{BAT}$$

The following formulas all based on the IC of ME4057-N.

The approximate ambient temperature at which the thermal feedback begins to protect the IC is:

$$T_A = 145^\circ\text{C} - P_D \theta_{JA}; \quad T_A = 145^\circ\text{C} - (V_{CC} - V_{BAT}) \times I_{BAT} \times \theta_{JA}$$

For example: The ME4057-N with 5V supply voltage through programmable provides full limiting current 800mA



to a charge lithium-ion battery with 3.75V voltage. If  $\theta_{JA}$  is  $63^{\circ}\text{C}/\text{W}$  (reference to PCB layout considerations), When ME4057-N begins to decrease the charge current, the ambient temperature about:

$$T_A = 145^{\circ}\text{C} - (5\text{V} - 3.75\text{V}) \times 800\text{mA} \times 63^{\circ}\text{C}/\text{W}$$
$$T_A = 145^{\circ}\text{C} - 1\text{W} \times 63^{\circ}\text{C}/\text{W} = 145^{\circ}\text{C} - 63^{\circ}\text{C} \quad T_A = 82^{\circ}\text{C}$$

ME4057-N can work in the condition of the temperature is below  $82^{\circ}\text{C}$ , but the charge current will pull down to below 800mA. In a fixed ambient temperature, the charge current is calculated to be approximately :

$$I_{\text{BAT}} = \frac{145^{\circ}\text{C} - T_A}{(\text{VCC} - V_{\text{BAT}}) * \theta_{\text{JA}}}$$

Just as Description of the Principle part talks about so, the current on PROG pin will reduce in proportion to the reduced charge current through thermal feedback. In ME4057-N design applications don't need to considerate the worst case of thermal condition, this point is importance, because if the junction temperature up to  $145^{\circ}\text{C}$ , IC will auto reduce the power dissipation.

### Thermal considerations

Because of the small size of the thin SOP8 package, it is important to use a good thermal PC board layout to maximize the available charge current. The thermal path for the heat generated by the IC is from the die to the copper lead frame, through the package leads, (especially the ground lead) to the PC board copper. The PC board copper is the heat sink. The footprint copper pads should be as wide as possible and expand out to larger copper areas to spread and dissipate the heat to the surrounding ambient. Other heat sources on the board, not related to the charger, must also be considered when designing a PC board layout because they will affect overall temperature rise and the maximum charge current.

### Add thermal regulation current

It will effective to decrease the power dissipation through reduce the voltage of both ends of the inner MOSFET. In the thermal regulation, this action of transporting current to battery will raise. One of the measure is through an external component(as a resistor or diode) to consume some power dissipation.

For example: The ME4057-N with 5V supply voltage through programmable provides full limiting current 800mA to a charge lithium-ion battery with 3.75V voltage. If  $\theta_{JA}$  is  $125^{\circ}\text{C}/\text{W}$ , so that at  $25^{\circ}\text{C}$  ambient temperature, the charge current is calculated to be approximately :

$$I_{\text{BAT}} = \frac{145^{\circ}\text{C} - 25^{\circ}\text{C}}{(\text{Vs} - I_{\text{BAT}} \times R_{\text{CC}} - V_{\text{BAT}}) \theta_{\text{JA}}}$$

In order to increase the thermal regulation charge current, can decrease the power dissipation of the IC through reducing the voltage (as show fig.3) of both two ends of the resistor which connecting in series with a 5V AC adapter.



With square equation to calculate IBAT :

$$I_{BAT} = \frac{(V_S - V_{BAT}) - \sqrt{(V_S - V_{BAT})^2 - \frac{4R_{CC}(145^\circ\text{C} - T_A)}{\theta_{JA}}}}{2R_{CC}}$$

If  $R_{CC}=0.25\Omega$ ,  $V_S=5V$ ,  $V_{BAT}=3.75V$ ,  $T_A=25^\circ\text{C}$  and  $\theta_{JA} = 125^\circ\text{C/W}$ , we can calculate the thermal regulation charge current:  $I_{BAT}=948\text{mA}$ . It means that in this structure it can output 800mA full limiting charge current at more high ambient temperature environment.

Although it can transport more energy and reduce the charge time in this application, but actually spread charge time, if ME4057-N stay in under-voltage state, when VCC becomes too low in voltage mode. Fig.4 shows how the voltage reduced with increase RCC value in this circuit. This technique will act the best function when in order to maintain the minimize the dimension of the components and avoid voltage decreased to minimize RCC.

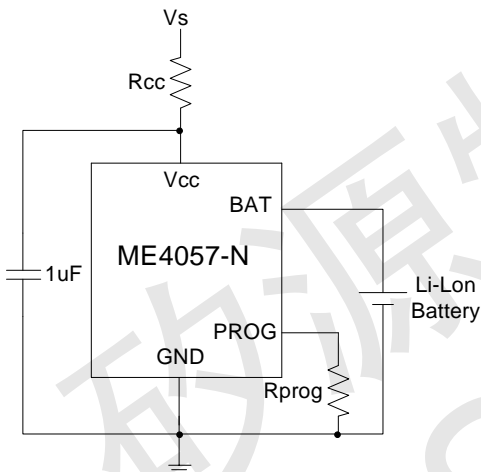

**Fig.3:A circuit to maximum the thermal regulation charge current**

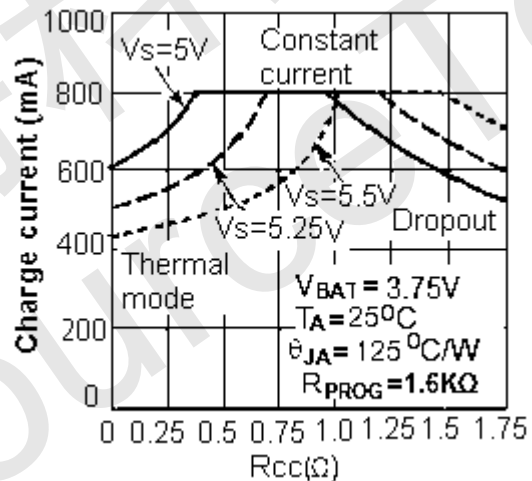

**Fig.4:The relationship curve between charge current with Rcc**

### VCC bypass capacitor

Many types of capacitors can be used for input bypassing, however, caution must be exercised when using multilayer ceramic capacitors. Because of the self-resonant and high Q characteristics of some types of ceramic capacitors, high voltage transients can be generated under some start-up conditions, such as connecting the charger input to a live power source. Adding a  $1.5\Omega$  resistor in series with a ceramic capacitor will minimize start-up voltage transients.

### Charging Current Soft Start

ME4057-N includes a soft start circuit which used to maximize to reduce the surge current in the begging of charge cycle. When restart a new charge cycle, the charging current ramps up from 0 to the full charging current within  $20\mu\text{s}$ . In the start process it can maximize to reduce the action which caused by surge current load.



## USB and Wall Adapter Power

## ME4057-N

ME4057-N allows charging from a USB port, a wall adapter can also be used to charge Li-Ion/Li-polymer batteries. Figure 5 shows an example of how to combine wall adapter and USB power inputs. A P-channel MOSFET, M1, is used to prevent back conducting into the USB port when a wall adapter is present and Schottky diode, D1, is used to prevent USB power loss through the 1K $\Omega$  pull-down resistor.

Generally, AC adaptor is able to provide bigger much current than the value of specific current limiting which is 500mA for USB port. So can rise charge current to 600mA with using a N-MOSFET (MN1) and an additional set resistor value as high as 10K $\Omega$ .

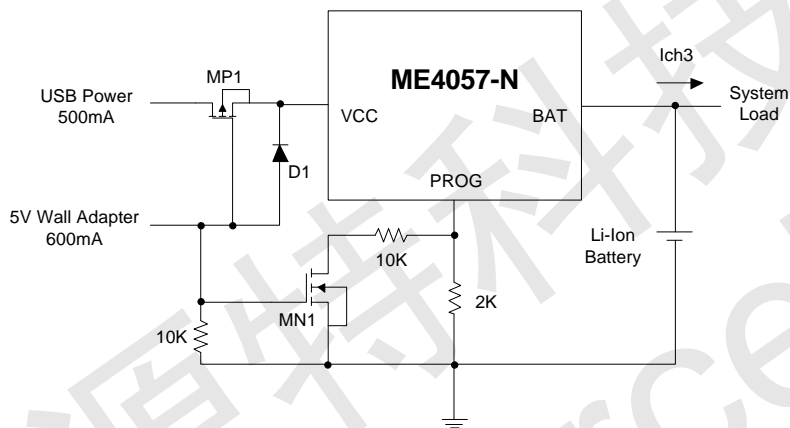
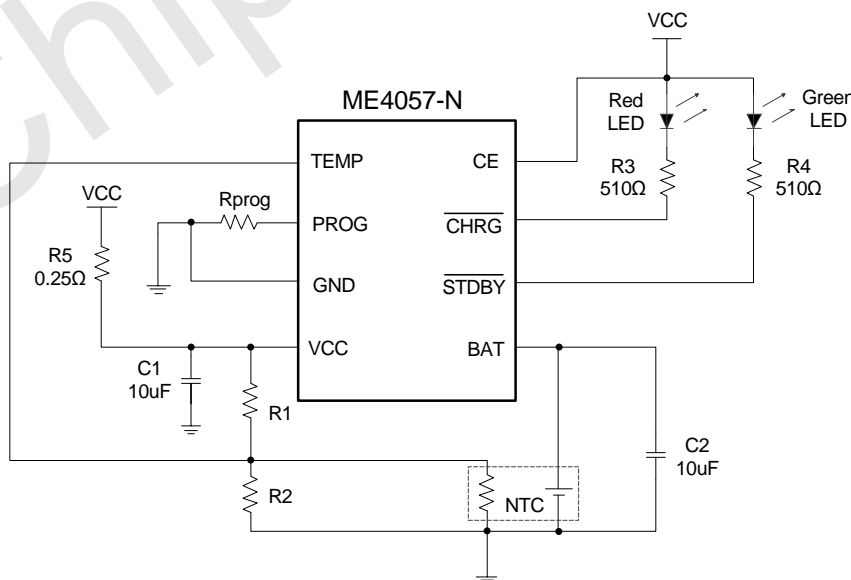

Fig.5:Combining Wall Adapter and USB Power

## Typical Application

Mainly used in Cellular telephones, MP3, MP4 players, digital still cameras, electronic dictionary, GPS, portable devices and vary chargers.

1. Suitable for the function of battery's temperature detection, the application of the indicator of battery's temperature anomaly and charge status.







## 2. Suitable for the application of USB power and the charge of wall adapter

ME4057-N

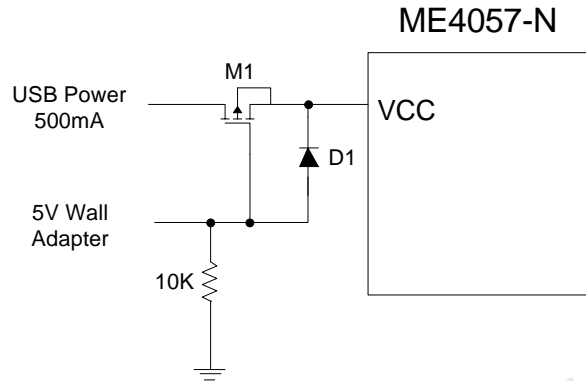

## 3. Suitable for charge status indicator, which the application not need battery's temperature detection.

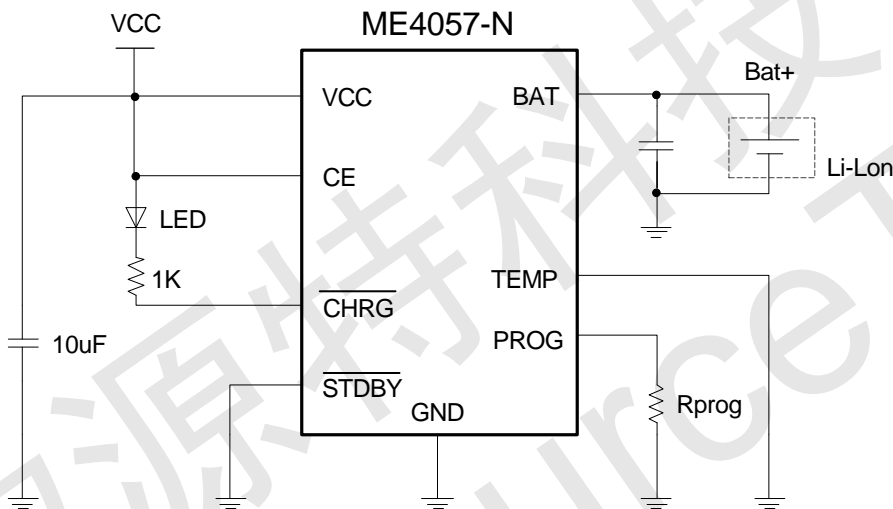

## 4. Suitable for the application which not need charge status indicator and battery's temperature detection.

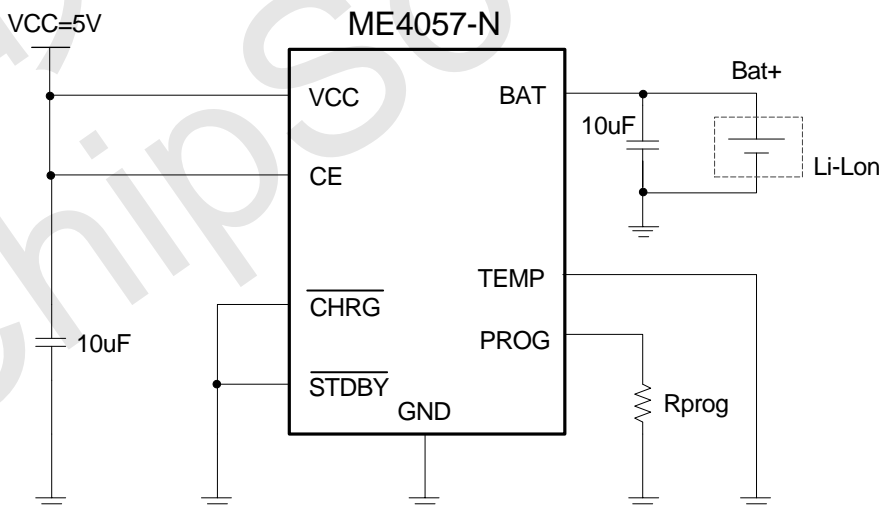



### 5. Add a resistor for power dissipation, Red LED for charge status, green LED for charge terminate state

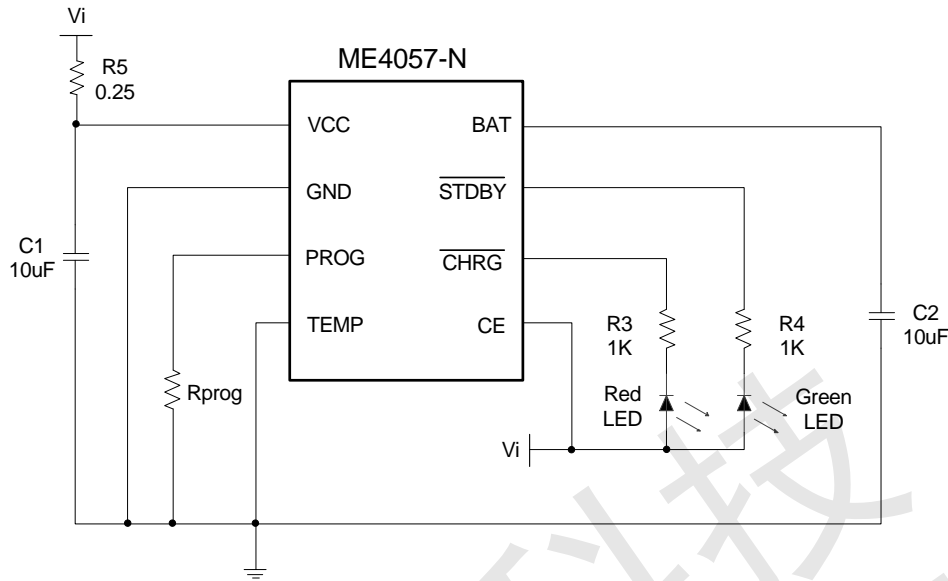

### Board Layout Considerations

- $R_{PROG}$  at PROG pin should be as close to ME4057-N as possible, also the parasitic capacitance at PROG pin should be kept as small as possible.
- The capacitance at VCC pin and BAT pin should be as close to ME4057-N as possible.
- During charging, ME4057-N's temperature may be high, the NTC thermistor should be placed far enough to ME4057-N so that the thermistor can reflect the battery's temperature correctly.
- It is very important to use a good thermal PC board layout to maximize charging current. The thermal path for the heat generated by the IC is from the die to the copper lead frame through the package lead (especially the ground lead) to the PC board copper, the PC board copper is the heat sink. The footprint copper pads should be as wide as possible and expand out to larger copper areas to spread and dissipate the heat to the surrounding ambient. Feed through vias to inner or backside copper layers are also useful in improving the overall thermal performance of the charger. Other heat sources on the board, not related to the charger, must also be considered when designing a PC board layout because they will affect overall temperature rise and the maximum charge current.
- The ability to deliver maximum charge current under all conditions require that the exposed metal pad on the back side of the ME4057-N package be soldered to the PC board ground. Failure to make the thermal contact between the exposed pad on the backside of the package and the copper board will result in larger thermal resistance.



## Packaging Information

ME4057-N

- Packaging Type: ESOP8

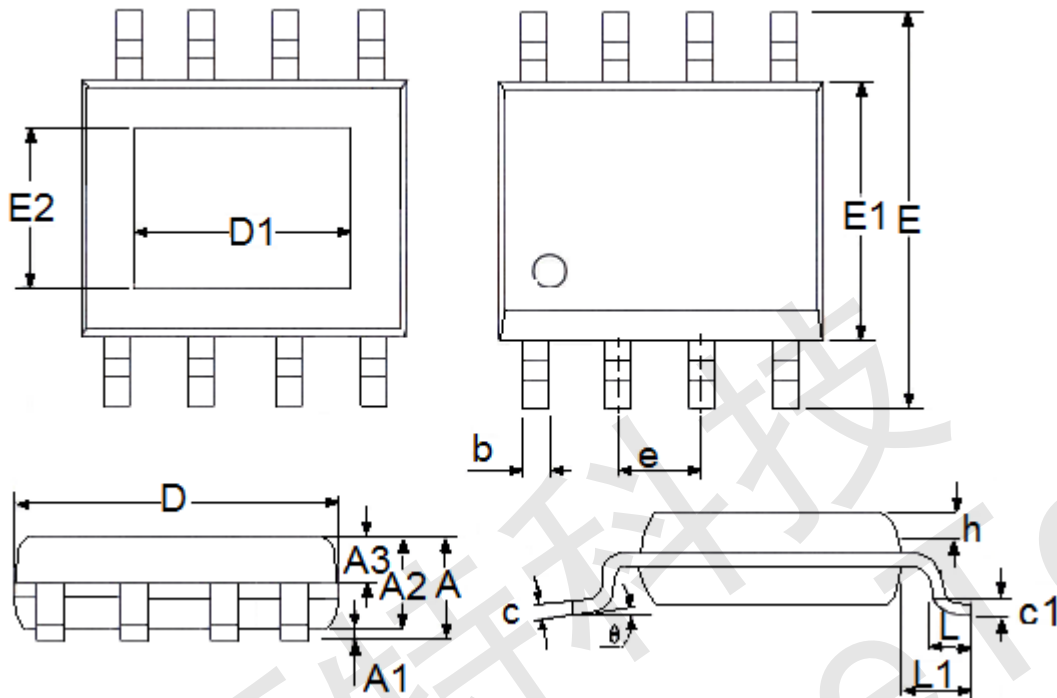

DIM	Millimeters		Inches	
	Min	Max	Min	Max
A	1.3	1.75	0.0512	0.0689
A1	0	0.2	0.0000	0.0079
A2	1.25	1.65	0.0492	0.0650
A3	0.5	0.7	0.0197	0.0276
b	0.33	0.51	0.0130	0.0201
c	0.17	0.25	0.0067	0.0098
D	4.7	5.1	0.1850	0.2008
E	5.8	6.2	0.2283	0.2441
E1	3.8	4	0.1496	0.1575
e	1.27(TYP)		0.05(TYP)	
h	0.25	0.5	0.0098	0.0197
L	0.4	1.27	0.0157	0.0500
L1	1.04(TYP)		0.0409(TYP)	
θ	0	8°	0.0000	8°
c1	0.25(TYP)		0.0098(TYP)	
D1	3.1(TYP)		0.122(TYP)	
E2	2.21(TYP)		0.087(TYP)	



● Packaging Type: DFN2\*2-8

ME4057-N

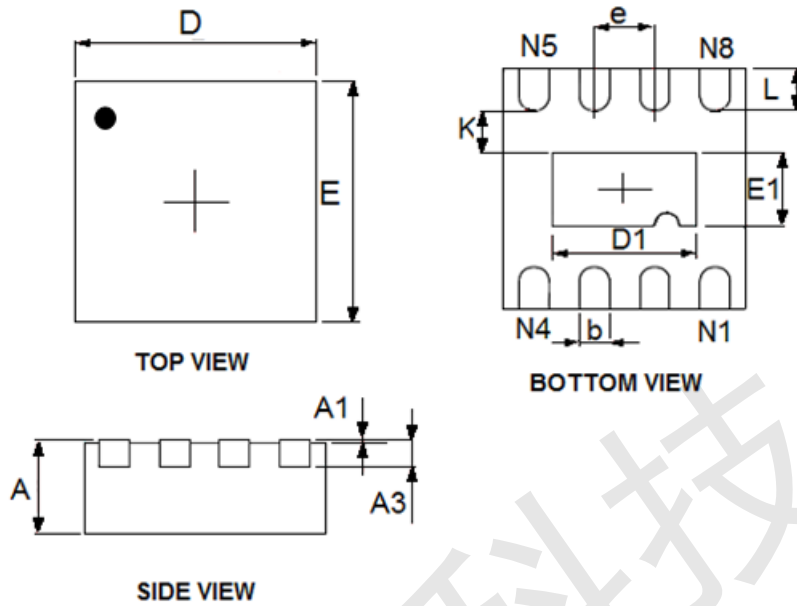

DIM	Millimeters		Inches	
	Min	Max	Min	Max
A	0.7	0.9	0.0276	0.0354
A1	0	0.05	0	0.002
A3	0.203(TYP)		0.008(TYP)	
b	0.18	0.3	0.0071	0.0118
D	1.9	2.1	0.0748	0.0827
E	1.9	2.1	0.0748	0.0827
E1	0.5	0.8	0.0197	0.0315
e	0.5(TYP)		0.0197(TYP)	
L	0.274	0.426	0.0108	0.0168
K	0.2	—	0.0079	—
D1	1.1	1.3	0.0433	0.0512



- The contents of this document will be updated with the product's improvement without prior notice. Please consult our sales staff before using this document to ensure that you are using the latest version.
- The application circuit examples described in this document are only used to indicate the representative use of the product and do not guarantee the design of mass production.
- Please use this product within the limits stated in this document. We will not be responsible for any damage caused by improper use.
- The products described in this document are not allowed to be used in equipment or devices that affect the human body without the written permission of our company, including but not limited to: health equipment, medical equipment, disaster prevention equipment, fuel control equipment, automobile equipment, aviation equipment and vehicle equipment.
- Although our company has always been committed to improving product quality and reliability, semiconductor products have a certain probability of malfunction or wrong work. To prevent personal injury or property damage caused by such accidents, please pay full attention to safety design, for example: Alternate design, fire protection design, and prevention of wrong action design.
- When exporting this product or this document overseas, you should abide by applicable import and export control laws.
- Copying or reprinting part or all of this document in any form without the permission of our company is strictly prohibited.