

## Features

- Inherently Matched LED Current
- High Efficiency:82%
- Drives Up to Five LEDs from 2.2V Supply
- 17V Over Voltage Protection
- Fast 1.4MHz Switching Frequency
- Requires Only 1 $\mu$ F Output Capacitors
- SOT-23-6 Package

## Applications

- Communication equipment
- White LED Backlight Display for PDA
- Pocket PC
- Handheld Devices
- Cellular Phones
- White LED display backlighting

## General Description

The TX5121 is a step-up DC/DC converter specifically designed to drive up to 5 series white LEDs with constant current. Series connection of the LEDs provides identical LED currents resulting in uniform brightness and eliminates the need for ballast resistors. The TX5121 switches at 1.4MHz, allowing the use of tiny external

components. A low 0.25V feedback voltage minimizes power loss in the current setting resistor for high efficiency. The OVP pin monitors the output voltage and turns off the converter whenever the LEDs are open.

The TX5121 is available in low profile SOT-23-6 package.

## Block Diagram

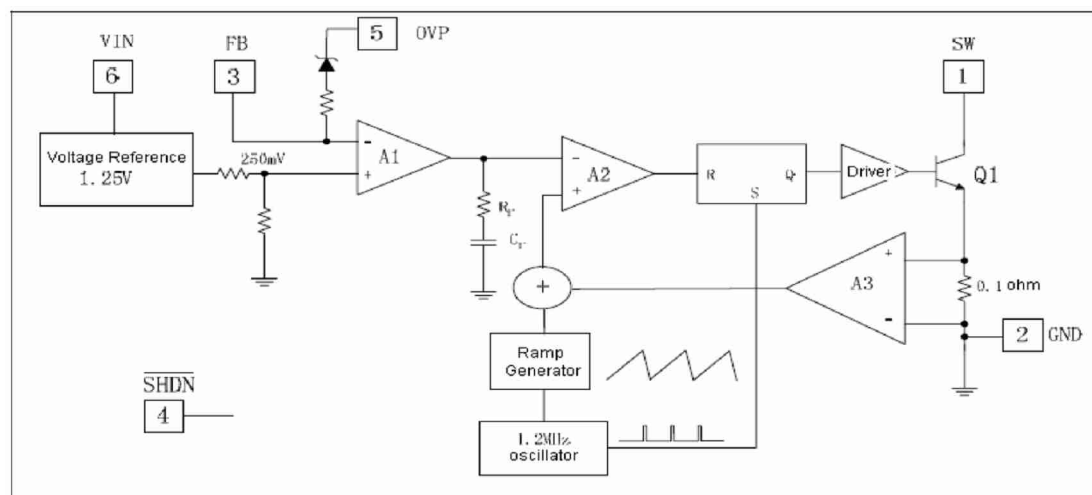

**Pin Assignment**

**SOT23-6 (Top view)**

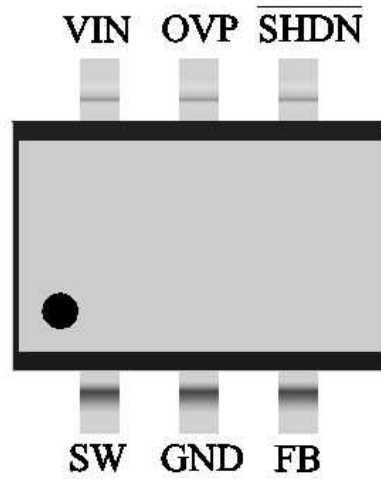

**Order Information**

TX5121①②

Designator	Symbol	Description
①	M	Package:SOT23-6
②	R	RoHS / Pb Free
	G	Halogen Free

**Typical Application Circuit**

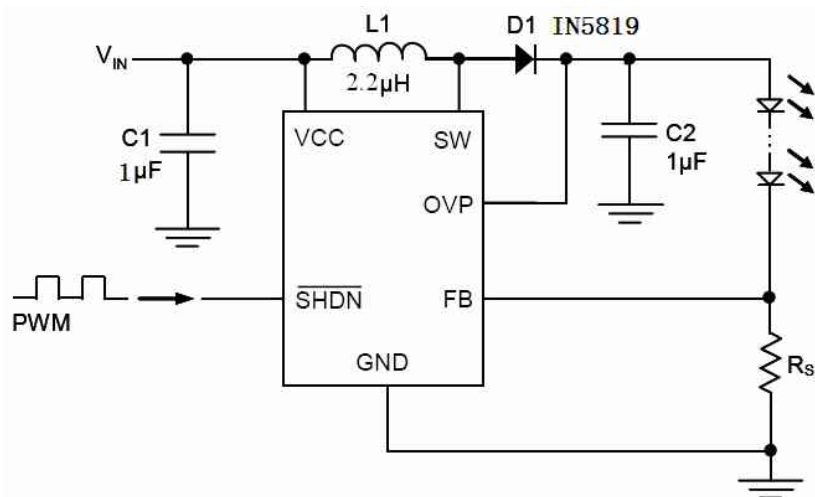

### Absolute Maximum Ratings

Input Voltage .....	6V	OVP Voltage.....	20V
FB Voltage .....	6V	SW Voltage.....	20V
SHDN Voltage .....	6V	Storage Temperature .....	-65 to 150°C
Continuous Power Dissipation.....	600mW	Operating Junction Temperature.....	-40 to 85°C

Note: These are stress ratings only. Stresses exceeding the range specified under “Absolute Maximum Ratings” may cause substantial damage to the device. Functional operation of this device at other conditions beyond those listed in the specification is not implied and prolonged exposure to extreme conditions may affect device reliability.

### Electrical Characteristics

V<sub>EN</sub>=3.8V; V<sub>IN</sub>=3.8V; T<sub>a</sub>=25°C

Parameter	Symbol	Test Conditions	Min	Typ	Max	Unit
Input Voltage	V <sub>IN</sub>	--	2.2	--	6.0	V
Feedback Voltage	V <sub>FB</sub>	I <sub>OUT</sub> =20 mA, 3LED	210	250	275	mV,
Switching Frequency	F <sub>SW</sub>	I <sub>OUT</sub> =20mA	1.1	1.4	1.5	MHz
SHDN Voltage High	V <sub>H</sub>	--	1.2	--	--	V
SHDN Voltage Low	V <sub>L</sub>	--	--	--	0.8	V
OVP Voltage	V <sub>ovp</sub>	--	--	20	--	V
FB Pin Bias Current	I <sub>FB</sub>	I <sub>OUT</sub> =20mA	50	100	200	nA
Supply Current	I <sub>IN</sub>	I <sub>OUT</sub> =0mA	--	3.0	5.0	mA
Shutdown Current	I <sub>OFF</sub>	V <sub>SHDN</sub> =0V	--	0.5	1.0	uA
Maximum Duty Cycle	D <sub>MAX</sub>		--	85	90	%
Switch Current Limit	I <sub>LIM</sub>		600	700	750	mA
Switch Leakage Current	I <sub>SW</sub>	V <sub>SW</sub> =5V	--	0.1	1	A
Switch V <sub>cesat</sub>	V <sub>SAT</sub>	I <sub>SW</sub> =250mA	--	300	--	mV

### Function Description

The TX5121 uses a constant frequency control scheme to provide excellent line and load regulation. Operation can be best understood by referring to the block diagram. At the start of each oscillator cycle, the SR latch is set, which turns on the power switch M1. An artificial ramp is generated to the positive terminal of the PWM comparator A2. When this voltage exceeds the level at the negative input of A2, the SR latch is reset turning off the power switch. The level at the negative input of A2 is set by the error amplifier A1, and is simply an amplified version of the difference between the feedback voltage and the reference voltage of 0.254V. In this manner, the error amplifier sets the correct peak current

---

level to keep the output in regulation. If the error amplifier's output increases, more current is delivered to the output, if it decreases, less current is delivered.

### **Shutdown**

The shutdown pin, SHDN, must not be allowed to float. When the SHDN pin voltage is taken below 0.8V, the internal MOSFET, voltage reference, error amplifier, comparators and biasing circuitry will all be switched off reducing the quiescent supply current to less than 1uA. If the SHDN pin has a value greater than 1.3V, then the device will be fully enabled and operational. This pin also can be used as a PWM signal from 100Hz to 1kHz to allow brightness control.

### **Over Voltage Protection**

The OVP function is designed to prevent damage to the internal NMOS switching transistor. When the output voltage rises above the OVP threshold voltage, typically 17V, the converter will clamp the output voltage to this level. When the output voltage returns to a value below the OVP threshold, it will automatically resume normal switching operation.

## **Application Information**

### **Inductor Selection**

A 10μF inductor is recommended for TX5121 applications. Small size and high efficiency are the major concerns for most TX5121 applications. Inductor with low core losses and small DCR (cooper wire resistance) at 1.4MHz are good choice for TX5121 applications.

### **Diode Selection**

Schottky diodes, with their low forward voltage drop and fast reverse recovery, are the ideal choices for TX5121 applications. The forward voltage drop of a Schottky diode represents the conduction losses in the diode, while the diode capacitance (CT or CD) represents the switching losses. For diode selection, both forward voltage drop and diode capacitance need to be considered. Schottky diodes with higher current ratings usually have lower forward voltage drop and larger diode capacitance, which can cause significant switching losses at the 1.4MHz switching frequency of the TX5121. A Schottky diode rated at 500mA is sufficient for most TX5121 applications.

### **Capacitor Selection**

The small size of ceramic capacitors makes them suitable for TX5121 applications. X5R and X7R types are recommended because they retain their capacitance over wider voltage and temperature ranges than other types such as Y5V or Z5U. A minimum 1μF capacitor for output is required for most applications. Larger input/output capacitor minimizes input/output ripple.

### **Dimming control**

A PWM signal is applied to the SHDN pin as shown in Figure 1. The magnitude of the PWM signal should be higher than the enable voltage of the SHDN pin, the LEDs operate with either zero or full current. The average LED current is proportional to the duty cycle of the applied PWM signal with a duty cycle increase resulting in higher LEDs brightness. Typical PWM frequencies should be between 100Hz and 1kHz.

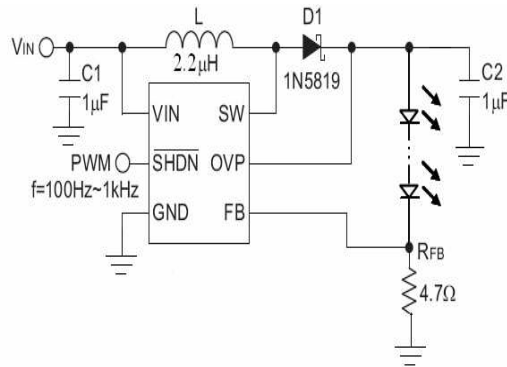

### Typical Performance Characteristics

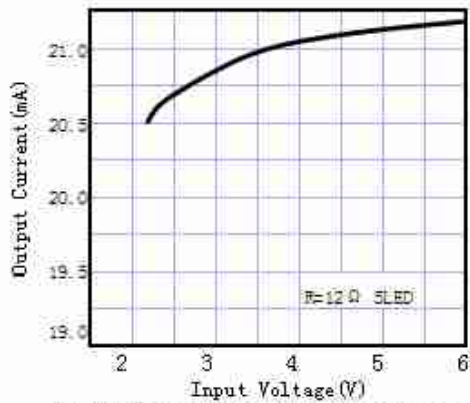

Fig1: Output Current VS Input Voltage

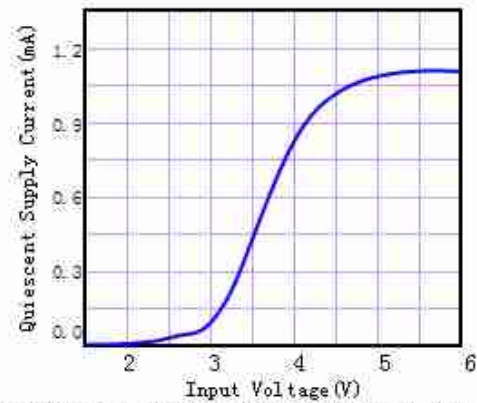

Fig2: Quiescent Supply Current VS Input Voltage

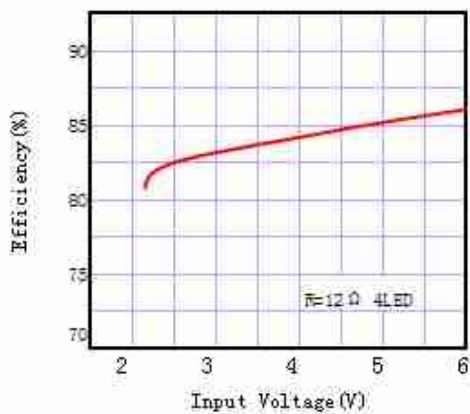

Fig3: Efficiency VS Input Voltage

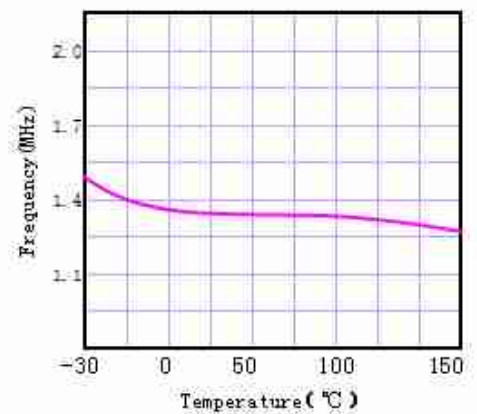

Fig4: Temperature VS Frequency

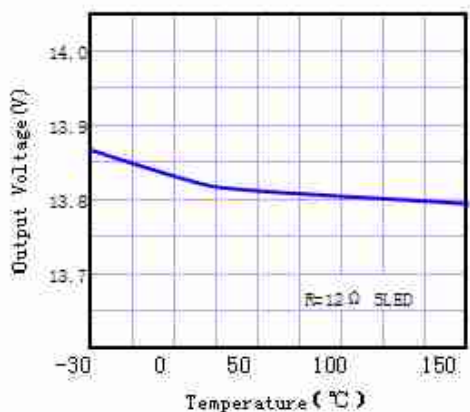
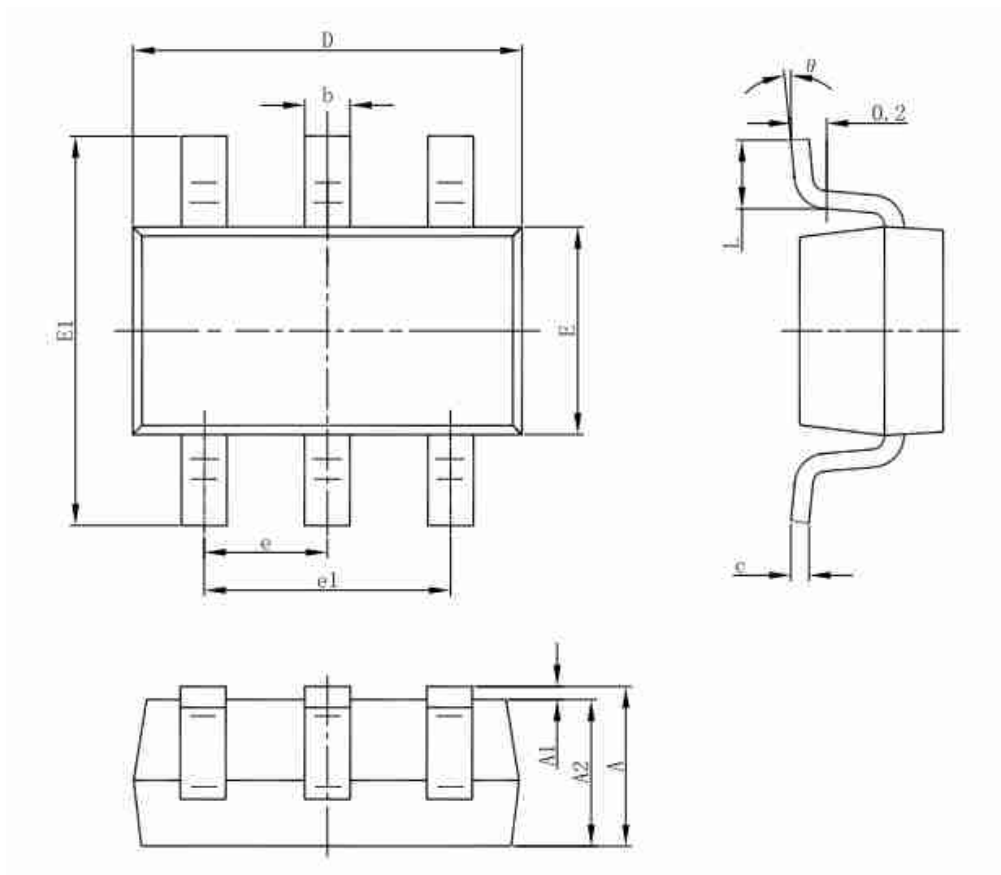

Fig4: Temperature VS Output Voltage

**Package Information**

**SOT-23-6L PACKAGE OUTLINE DIMENSIONS**



Symbol	Dimensions In Millimeters		Dimensions In Inches	
	Min	Max	Min	Max
A	1.050	1.250	0.041	0.049
A1	0.000	0.100	0.000	0.004
A2	1.050	1.150	0.041	0.045
b	0.300	0.500	0.012	0.020
c	0.100	0.200	0.004	0.008
D	2.820	3.020	0.111	0.119
E	1.500	1.700	0.059	0.067
E1	2.650	2.950	0.104	0.116
e	0.950(BSC)		0.037(BSC)	
e1	1.800	2.000	0.071	0.079
L	0.300	0.600	0.012	0.024
θ	0°	8°	0°	8°