

Features

- Low power consumption:8uA (Typ.)
- Low voltage drop:0.4V@100mA(Typ.)
- Standby Mode: 0.1uA
- Low temperature coefficient
- Output Voltage Range: 0.9V~5V
- Good line Regulation:0.05%/V
- High Ripple Rejection: 60dB@100Hz(Typ.)
- Output voltage accuracy: tolerance $\pm 2\%$
- Build-in Enable/Output Current Limit circuit
- SOT23, SOT23-5 and SOT89 package

Applications

- Cellular phones
- Wireless Communication equipment
- Cordless phones
- Portable games
- Cameras, Video cameras
- Reference voltage sources

General Description

The TX6221 series is a high accuracy, low noise, high speed, low dropout CMOS regulator with high ripple rejection. The series includes a reference voltage source, an error amplifier, and a phase compensation circuit. The CE function enables the entire circuit to be in stand-by state by inputting low level signal. Output voltage is selectable in 0.05V increments within a range of 0.80V~5.00V, using the laser

trimming technology set in factory. The current limiter's fold-back circuit also operates as a short circuit protection and an output current limiter at the output pin. The series achieves a fast response with only 8uA of low power consumption. Also the series has low dropout voltage characteristics, which is 330mV at $I_{OUT}=100mA$ and $V_{out}=5.0V$.

Order Information

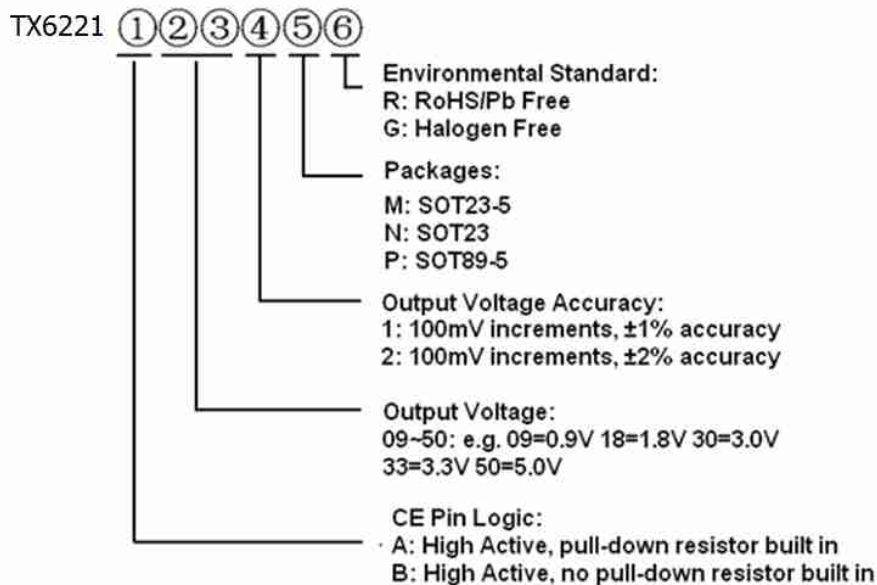

Package and Pin assignment

SOT23-5 (Top view)

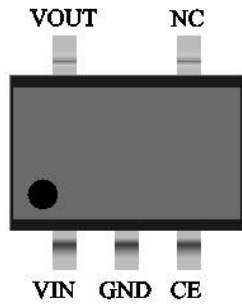

SOT89-5 (Top view)

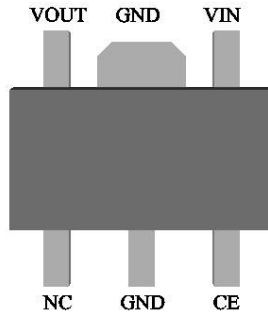

SOT23 (Top view)

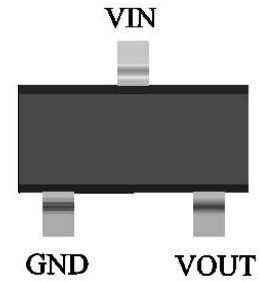

Block Diagram

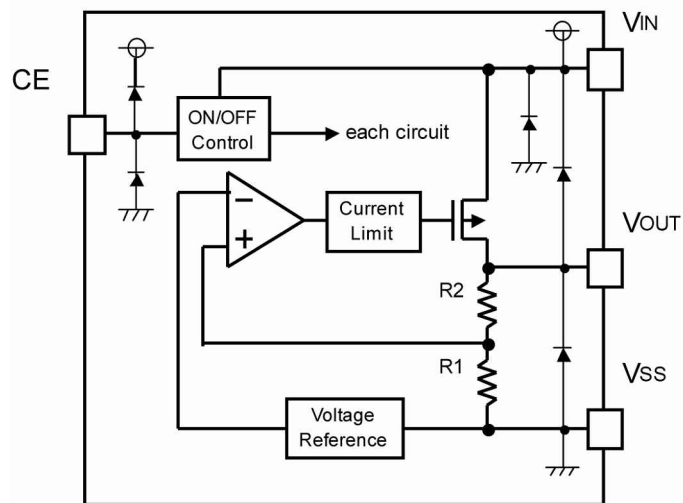

Typical Application Circuit

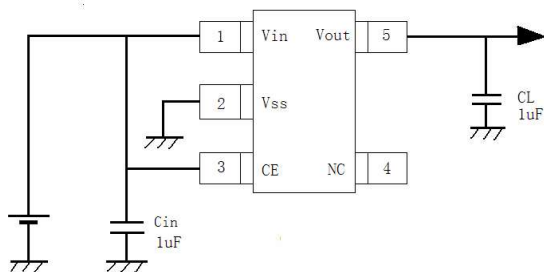

Marking Rule

SOT23-5(Top view)

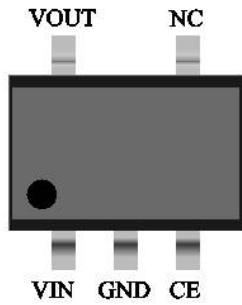

SOT89-5 (Top view)

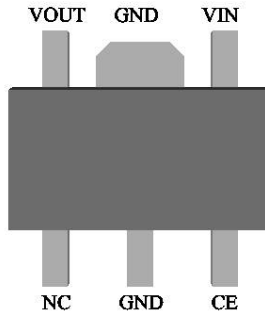

SOT23 (Top view)

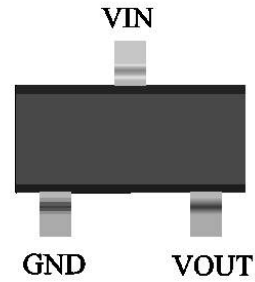

① Represents product series

Mark	Product Series
9	TX6221xxxxxx

② Represents type of regulator

Mark				Product series
Vout 100mV Increments		Vout 50mV Increments		
Vout:0.1~3.0V	Vout:3.1~6.0V	Vout:0.15~3.05V	Vout:3.15~6.05	
X	B	F	M	TX6221xxxxx

③ Represents output Voltage

Mark	Output Voltage(V)				Mark	Output Voltage(V)			
0	-	3.1	-	3.15	F	1.6	4.6	1.65	4.65
1	-	3.2	-	3.25	H	1.7	4.7	1.75	4.75
2	-	3.3	-	3.35	K	1.8	4.8	1.85	4.85
3	-	3.4	-	3.45	L	1.9	4.9	1.95	4.95
4	-	3.5	-	3.55	M	2.0	5.0	2.05	-
5	-	3.6	-	3.65	N	2.1	-	2.15	-
6	-	3.7	-	3.75	P	2.2	-	2.25	-
7	-	3.8	-	3.85	R	2.3	-	2.35	--
8	0.9	3.9	0.95	3.95	S	2.4	-	2.45	-
9	1.0	4.0	1.05	4.05	T	2.5	-	2.55	-
A	1.1	4.1	1.15	4.15	U	2.6	-	2.65	-
B	1.2	4.2	1.25	4.25	V	2.7	-	2.75	-
C	1.3	4.3	1.35	4.35	X	2.8	-	2.85	-
D	1.4	4.4	1.45	4.45	Y	2.9	-	2.95	-
E	1.5	4.5	1.55	4.55	Z	3.0	-	3.05	-

④ Represents production lot number

X

Absolute Maximum Ratings

Supply Voltage-0.3V to 15V Storage Temperature-50°C to 125°C

Operating Temperature-40°C to 85°C

Note: These are stress ratings only. Stresses exceeding the range specified under “Absolute Maximum Ratings” may cause substantial damage to the device. Functional operation of this device at other conditions beyond those listed in the specification is not implied and prolonged exposure to extreme conditions may affect device reliability.

Thermal Information

Symbol	Parameter	Package	Max.	Unit
θ_{JA}	Thermal Resistance (Junction to Ambient) (Assume no ambient airflow, no heat sink)	SOT23-3	500	°C/W
		SOT23-5	500	°C/W
		SOT89-5	200	°C/W
P_D	Power Dissipation	SOT23-3	0.20	W
		SOT23-5	0.20	W
		SOT89-5	0.50	W

 Note: P_D is measured at $T_a = 25^\circ\text{C}$

Electrical Characteristics

TX6221 for any output voltage

 ($T_a = 25^\circ\text{C}$)

Parameter	Symbol	Conditions	Min.	Typ.	Max.	Unit
Output Voltage	V_{out}	$V_{in} = V_{out} + 1V$ $1.0\text{mA} \leq I_{out} \leq 30\text{mA}$	$V_{out} \times 0.98$	--	$V_{out} \times 1.02$	V
Output Current*1	I_{out}	$V_{in} - V_{out} = 1V$	--	350	--	mA
Low dropout*2	V_{drop}	Refer to the next table				
Line Regulation	$\Delta V_{out} / (V_{in} - V_{out})$	$1.6V \leq V_{in} \leq 8V$ $I_{out} = 40\text{mA}$	--	0.05	0.2	%/V
Load Regulation	$\Delta V_{out} / \Delta I_{out}$	$V_{in} = V_{out} + 1V$ $1.0\text{mA} \leq I_{out} \leq 80\text{mA}$	--	12	30	mV
Output voltage Temperature Coefficiency	$\Delta V_{out} / (T_a - V_{out})$	$I_{out} = 30\text{mA}$ $0^\circ\text{C} \leq T_a \leq 70^\circ\text{C}$	--	± 100	--	Ppm/°C
Supply Current	I_{ss1}	--	--	8	10	uA
Input Voltage	V_{in}	--	--	--	12	V
PSRR	PSRR	$F = 100\text{Hz}$ $V_{in} = V_{out} + 1V$	--	60	--	dB
Output Noise	EN	$BW = 10\text{Hz} \sim 100\text{kHz}$	--	27	--	uVrms

Packaging Information

SOT23-5 Outline Dimensions

 Web: <http://www.ChipSourceTek.com>

FAX: 0755-27594792

TEL: 0755-27595155 27595165 29359583 29359586

E-mail: InFo@ChipSourceTek.com

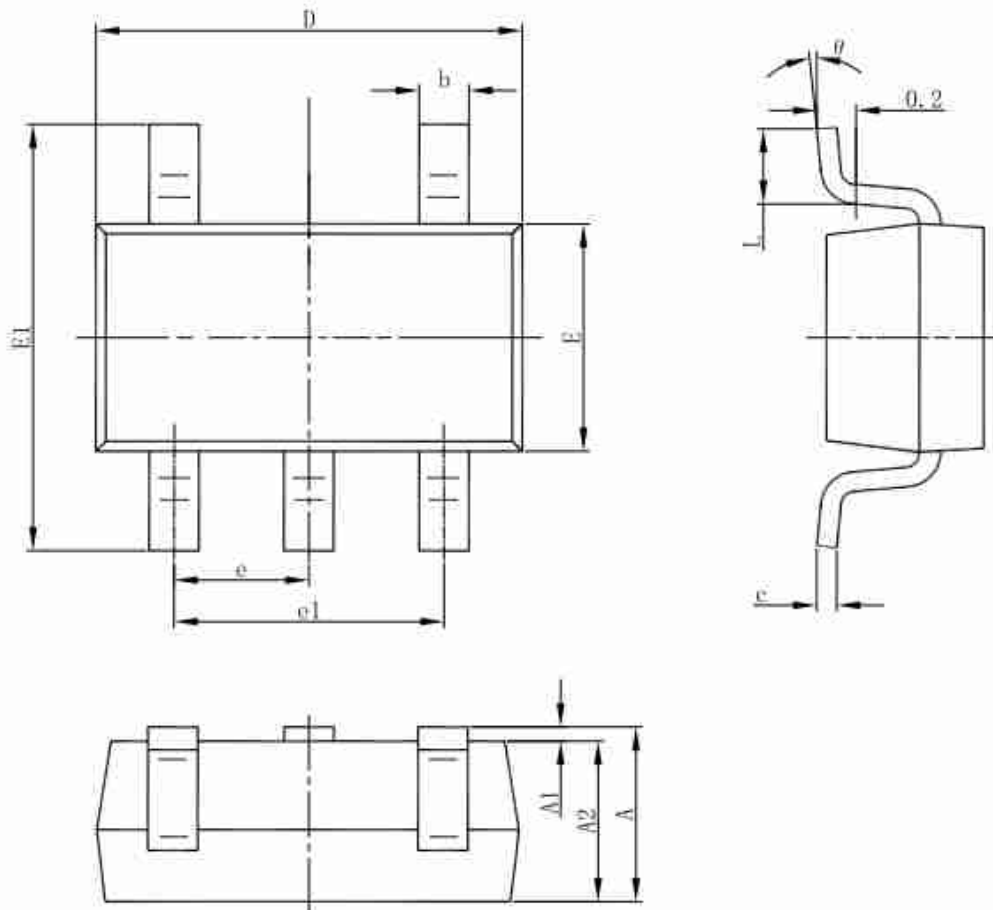

Symbol	Dimensions In Millimeters		Dimensions In Inches	
	Min	Max	Min	Max
A	1.050	1.250	0.041	0.049
A1	0.000	0.100	0.000	0.004
A2	1.050	1.150	0.041	0.045
b	0.300	0.500	0.012	0.020
c	0.100	0.200	0.004	0.008
D	2.820	3.020	0.111	0.119
E	1.500	1.700	0.059	0.067
E1	2.650	2.950	0.104	0.116
e	0.950(BSC)		0.037(BSC)	
e1	1.800	2.000	0.071	0.079
L	0.300	0.600	0.012	0.024
θ	0°	8°	0°	8°

SOT89-5 Outline Dimensions

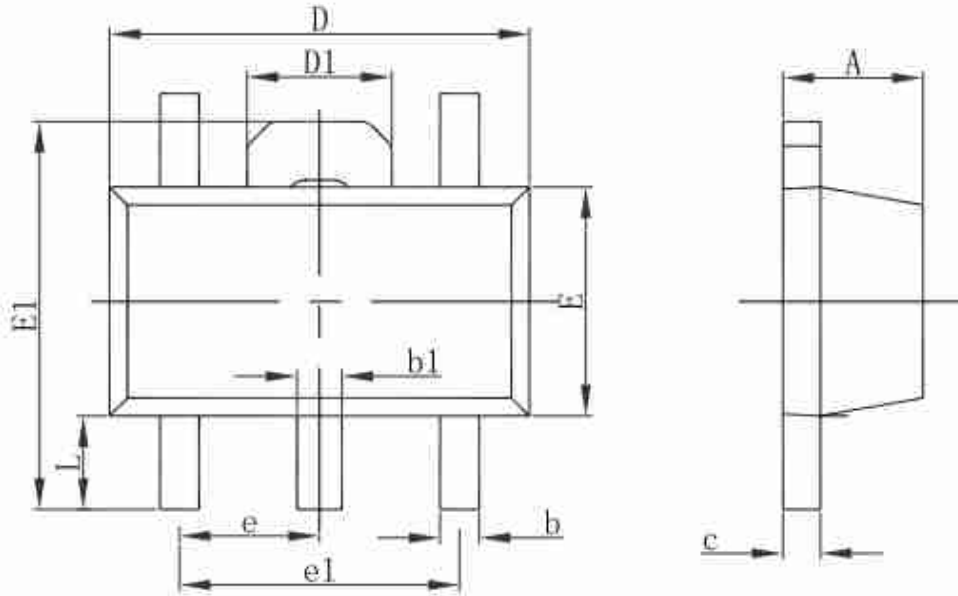

Symbol	Dimensions In Millimeters		Dimensions In Inches	
	Min.	Max.	Min.	Max.
A	1.400	1.600	0.055	0.063
b	0.320	0.520	0.013	0.020
b1	0.380	0.580	0.015	0.023
c	0.350	0.440	0.014	0.017
D	4.400	4.600	0.173	0.181
D1	1.550 REF.		0.061 REF.	
E	2.300	2.600	0.091	0.102
E1	3.940	4.250	0.155	0.167
e	1.500 TYP.		0.060 TYP.	
e1	3.000 TYP.		0.118 TYP.	
L	0.900	1.200	0.035	0.047

SOT23 Outline Dimensions

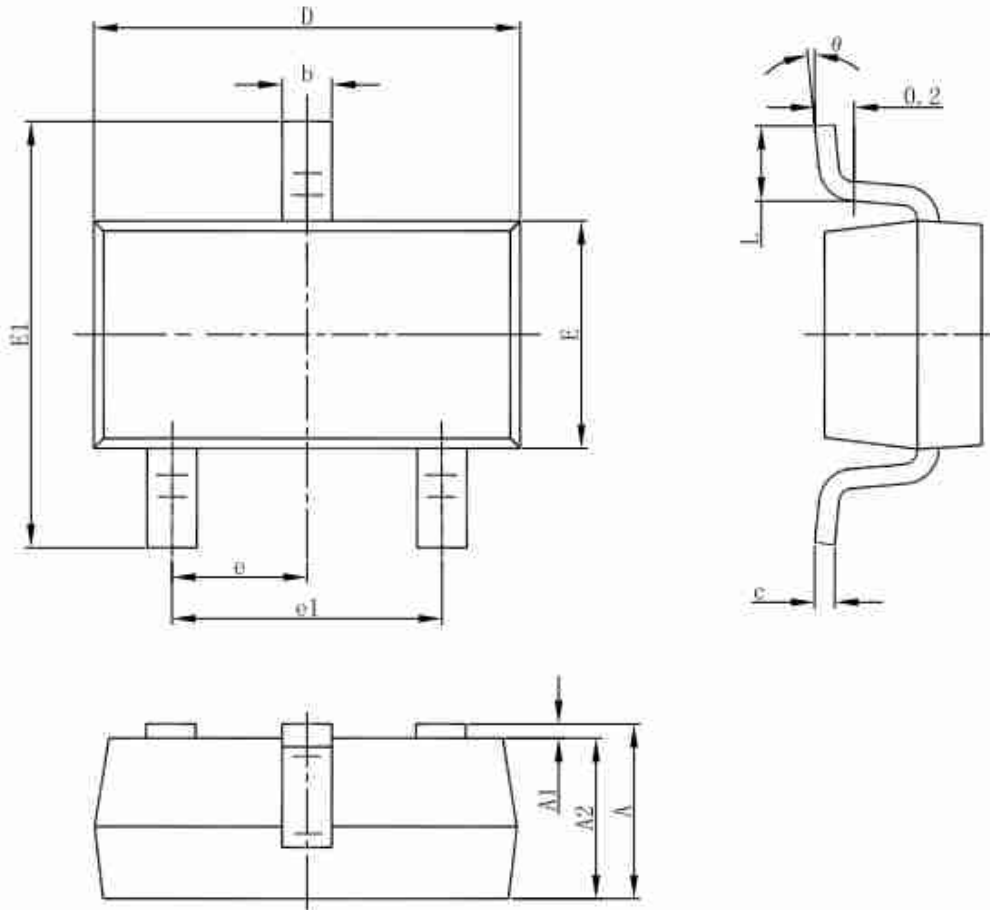

Symbol	Dimensions In Millimeters		Dimensions In Inches	
	Min	Max	Min	Max
A	1.050	1.250	0.041	0.049
A1	0.000	0.100	0.000	0.004
A2	1.050	1.150	0.041	0.045
b	0.300	0.500	0.012	0.020
c	0.100	0.200	0.004	0.008
D	2.820	3.020	0.111	0.119
E	1.500	1.700	0.059	0.067
E1	2.650	2.950	0.104	0.116
e	0.950(BSC)		0.037(BSC)	
e1	1.800	2.000	0.071	0.079
L	0.300	0.600	0.012	0.024
θ	0°	8°	0°	8°

©