



PE7N70J N-Channel Enhancement Mode Power MOSFET

PE7N70J Description

The PE7N70J uses self-aligned planar technology to reduce conduction loss, improve switching performance and enhance avalanche energy. It can be used in a wide variety of applications.

PE7N70J General Features

- $V_{DS} = 700V$, $I_D = 7A$
- $R_{DS(ON)} < 1.55\Omega @ V_{GS} = 10V$
- High Power and current handling capability
- Lead free product is acquired

PE7N70J Application

- PWM applications
- Load switch
- Power management

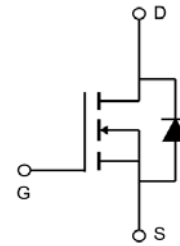

Schematic diagram

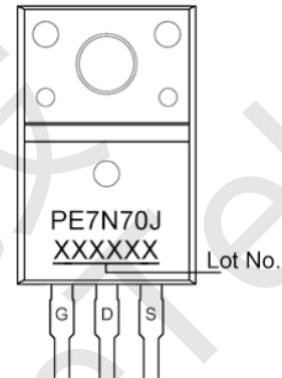

Marking and pin assignment



TO-220F

PE7N70J Absolute Maximum Ratings (TC=25°C unless otherwise noted)

Parameter	Symbol	Rating	Unit
Drain-Source Voltage	V_{DS}	700	V
Gate-Source Voltage	V_{GS}	± 30	V
Drain Current-Continuous	I_D	7	A
Drain Current-Continuous (TC=100°C)	$I_D(T_C=100^\circ C)$	4.5	A
Pulsed Drain Current (Note 1)	I_{DM}	28	A
Maximum Power Dissipation	P_D	50	W
Single Pulsed Avalanche Energy (L=10.6mH)	E_{AS}	260	mJ
Operating Junction and Storage Temperature Range	T_J, T_{STG}	-55 To 150	°C

PE7N70J Thermal Characteristic

Thermal Resistance, Junction-to-Case	$R_{\theta JC}$	2.5	°C/W
Thermal Resistance, Junction-to-Ambient (Note 2)	$R_{\theta JA}$	43.3	°C/W



PE7N70J Electrical Characteristics (TC=25°C unless otherwise noted)

Parameter	Symbol	Condition	Min	Typ	Max	Unit
Off Characteristics						
Drain-Source Breakdown Voltage	BV_{DSS}	$V_{GS}=0V, I_D=250\mu A$	705	-	-	V
Zero Gate Voltage Drain Current	I_{DSS}	$V_{DS}=700V, V_{GS}=0V$	-	-	1	μA
Gate-Body Leakage Current	I_{GSS}	$V_{GS}=\pm 20V, V_{DS}=0V$	-	-	± 100	nA
On Characteristics (Note 3)						
Gate Threshold Voltage	$V_{GS(th)}$	$V_{DS}=V_{GS}, I_D=250\mu A$	2.9	3.5	4	V
Drain-Source On-State Resistance	$R_{DS(ON)}$	$V_{GS}=10V, I_D=4A$	-	1.4	1.55	Ω
Dynamic Characteristics (Note 4)						
Input Capacitance	C_{iss}	$V_{DS}=25V, V_{GS}=0V,$ $F=1.0MHz$	-	1180	-	pF
Output Capacitance	C_{oss}		-	90	-	pF
Reverse Transfer Capacitance (Note 4)	C_{rss}		-	4.4	-	pF
Gate Resistance	R_g	$V_{DS}=0V, V_{GS}=0V, F=1.0MHz$	-	2.5	-	Ω
Switching Characteristics						
Turn-on Delay Time	$t_{d(on)}$	$V_{DS}=520V, I_D=7A,$ $V_{GS}=10V, R_G=3.3\Omega$	-	15	-	nS
Turn-on Rise Time	t_r		-	7.5	-	nS
Turn-Off Delay Time	$t_{d(off)}$		-	32	-	nS
Turn-Off Fall Time	t_f		-	14	-	nS
Total Gate Charge	Q_g	$V_{DS}=520V, I_D=7A,$ $V_{GS}=10V$	-	25.6	-	nC
Gate-Source Charge	Q_{gs}		-	5.3	-	nC
Gate-Drain Charge	Q_{gd}		-	14.7	-	nC
Drain-Source Diode Characteristics						
Diode Forward Voltage (Note 3)	V_{SD}	$V_{GS}=0V, I_S=1A$	-	0.8	1.2	V
Diode Forward Current	I_S		-	-	7	A
Body Diode Reverse Recovery Time	t_{rr}	$I_F=7A, di/dt=100A/\mu s$	-	315	-	ns
Body Diode Reverse Recovery Charge	Q_{rr}		-	1.52	-	μC

Notes:

1. Repetitive Rating: Pulse width limited by maximum junction temperature.
2. The device in a still air environment with $T_A=25^\circ C$
3. Pulse Test: Pulse Width $\leq 300\mu s$, Duty Cycle $\leq 2\%$.
4. Guaranteed by design, not subject to product.



PE7N70J Typical Electrical and Thermal Characteristics

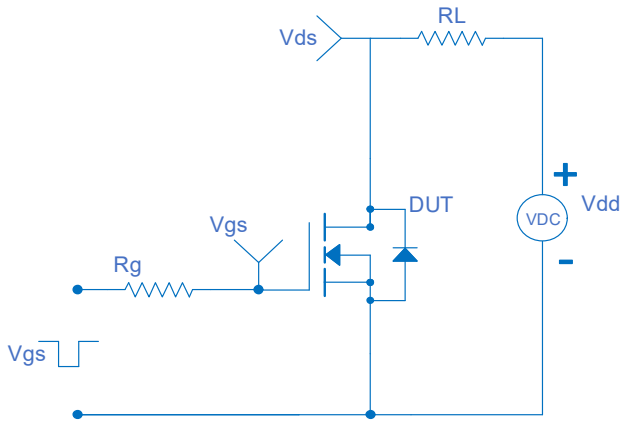

Figure 1 Switching Test Circuit

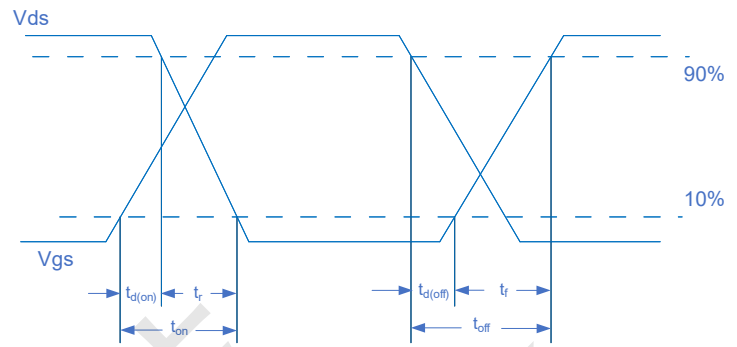

Figure 2 Switching Waveform

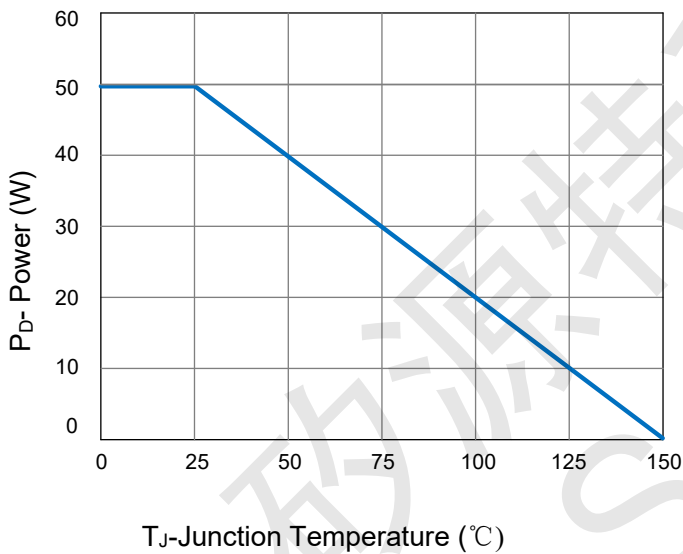

Figure 3 Power De-rating

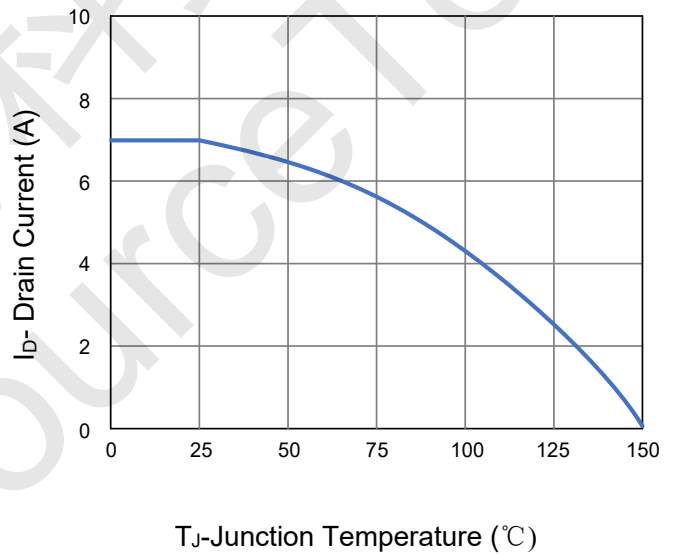

Figure 4 Drain Current

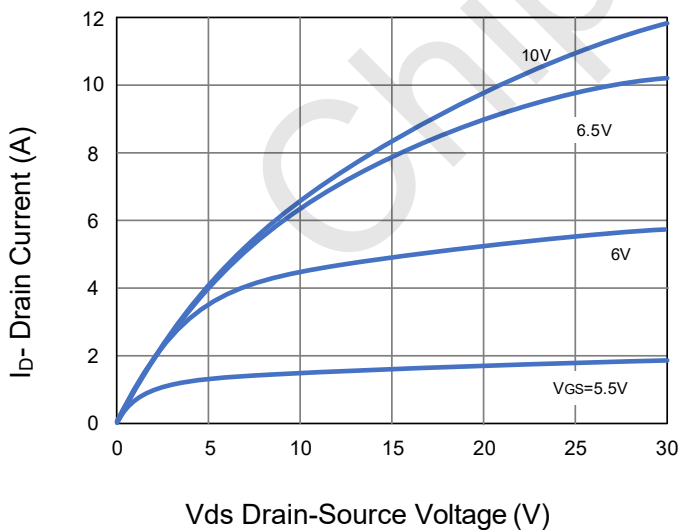

Figure 5 Output Characteristics

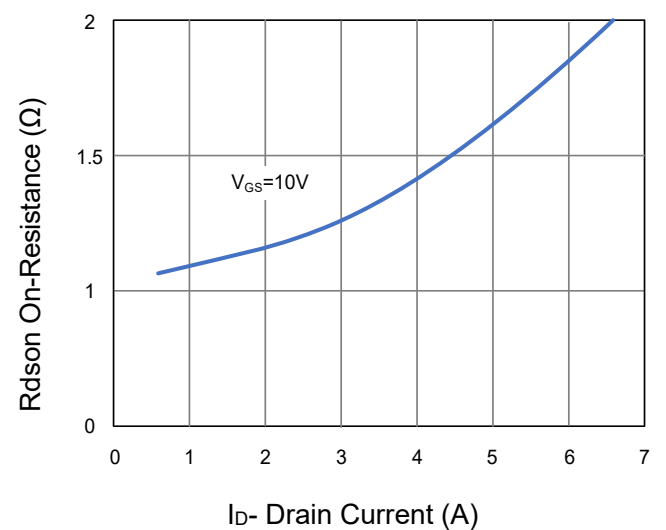

Figure 6 Rdson vs Drain Current

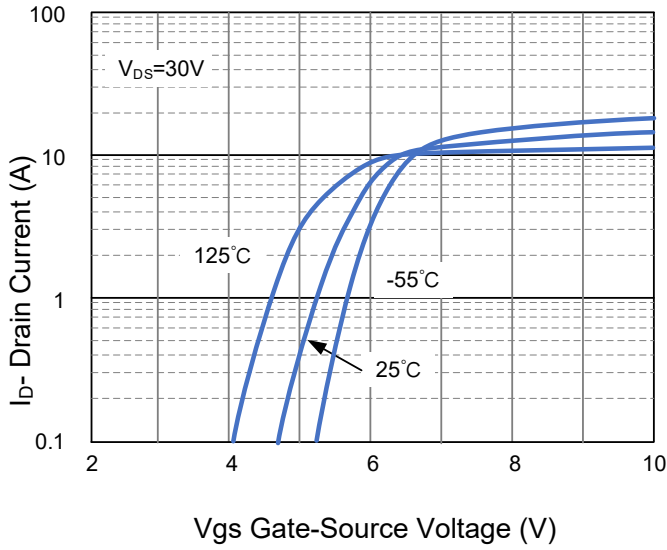

Figure 7 Transfer Characteristics

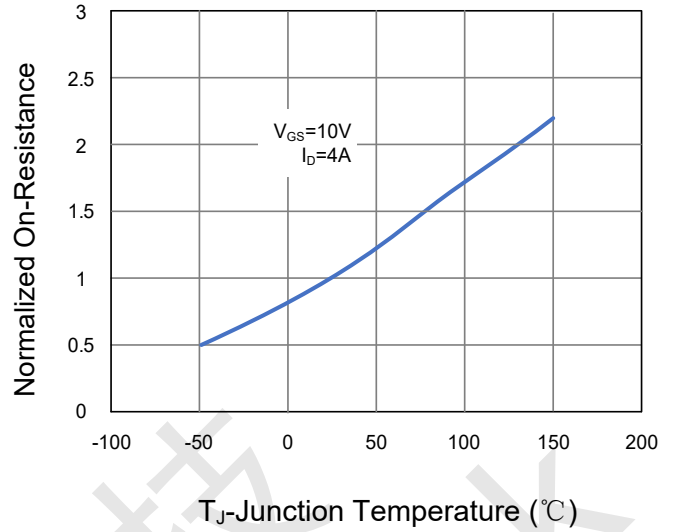

Figure 8 R_{dson} vs Junction Temperature

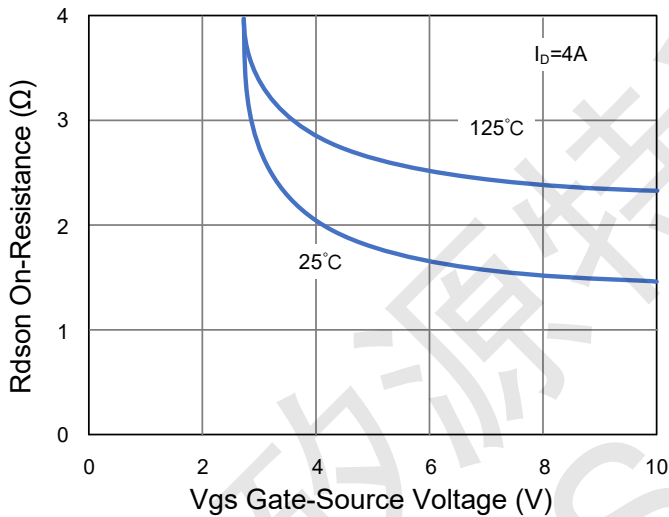

Figure 9 R_{dson} vs V_{GS}

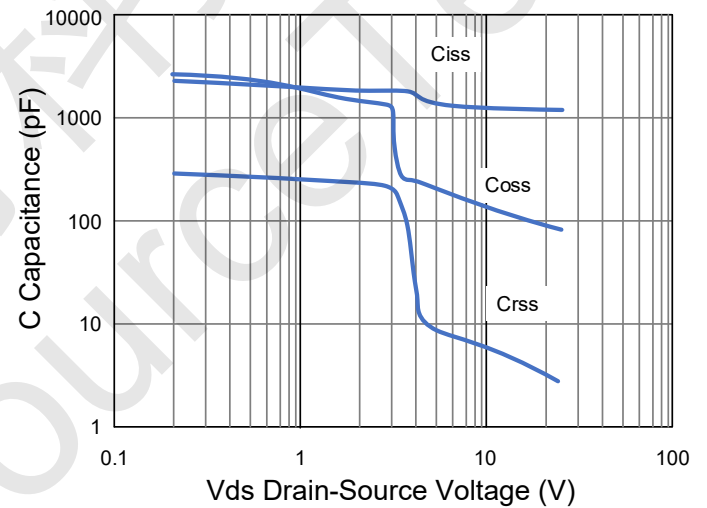

Figure 10 Capacitance vs V_{DS}

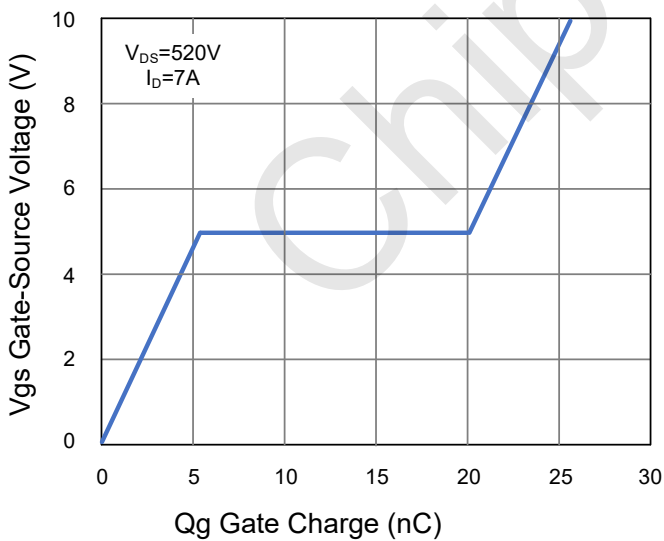

Figure 11 Gate Charge

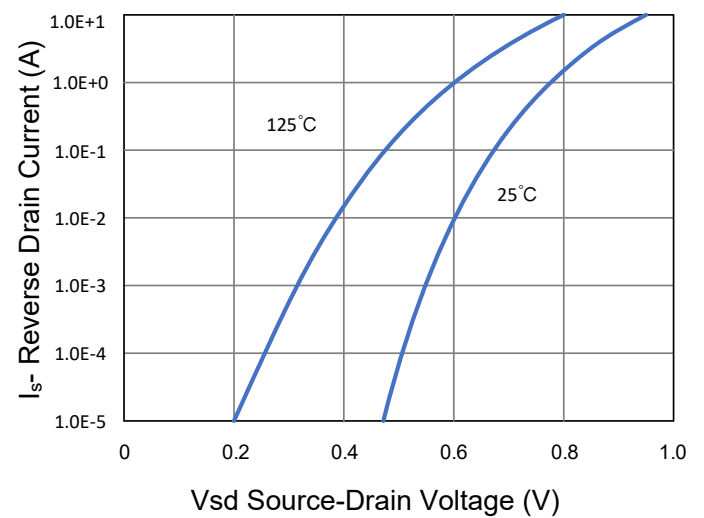

Figure 12 Source- Drain Diode Forward

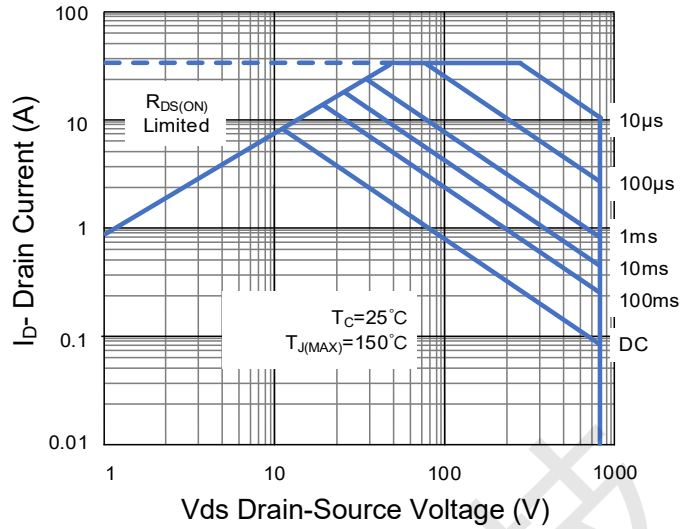

Figure 13 Safe Operation Area

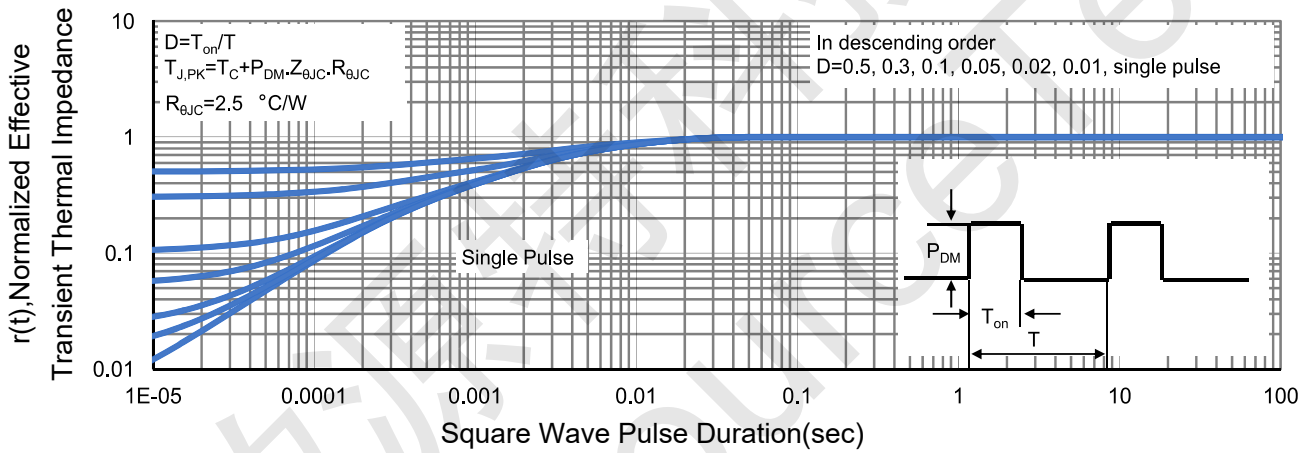
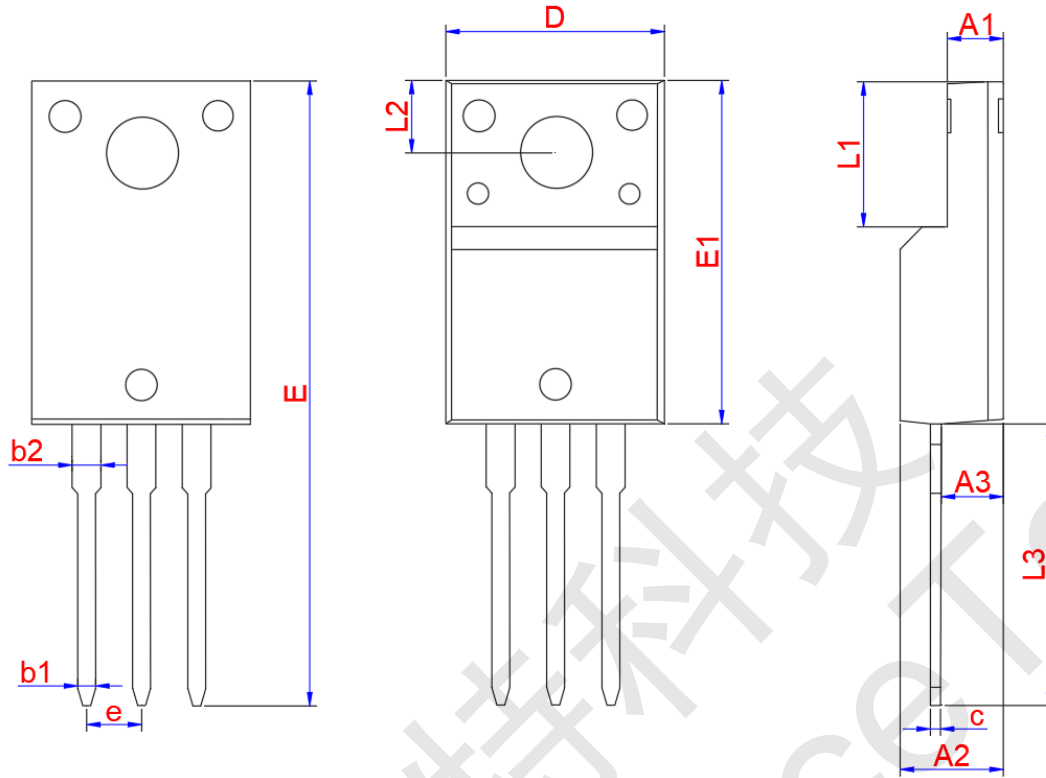

Figure 14 Normalized Maximum Transient Thermal Impedance



PE7N70J TO-220F Package Information



Symbol	Dimensions In Millimeters		
	Min.	Typ.	Max.
A1	2.440	2.540	2.640
A2	4.600	4.700	4.800
A3	2.730	2.830	2.930
b1	0.750	0.800	0.850
b2	1.230	1.280	1.330
c	0.450	0.500	0.550
D	10.060	10.160	10.260
E	28.650	28.850	29.050
E1	15.770	15.870	15.970
e	2.54 TYP.		
L1	6.68 REF		
L2	3.30 REF		
L3	12.830	12.980	13.130