

# PAM8013/PAM8015

## 3W MONO CLASS D AUDIO AMPLIFIER

### Description

The PAM8013/PAM8015 is a 3W mono filter-less class-D amplifier with high PSRR and differential input that eliminate noise and RF rectification.

Features like greater than 90% efficiency and small PCB area make the PAM8013/PAM8015 Class-D amplifier ideal for portable applications. The output uses a filter-less architecture minimizing the number of external components and PCB area whilst providing a high performance, simple and lower cost system.

The PAM8013/PAM8015 features short circuit protection and thermal shutdown.

The PAM8013/PAM8015 is available in U-FLGA1515-9 packages.

### Features

- Ultra Low EMI, -20dB Better Than FCC Class-B @ 300MHz
- High Efficiency up to 90% @1W with an 8Ω Speaker
- Shutdown Current <1μA
- 3W@10% THD Output with a 4Ω Load at 5V Supply
- Demanding Few External Components
- Superior Low Noise without Input
- Supply Voltage from 2.8V to 5.5V
- Short Circuit Protection
- Thermal Shutdown
- Available in Space Saving U-FLGA1515-9 Packages
- Pb-Free Package

### Pin Assignments

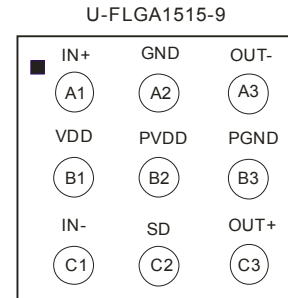

PAM8013

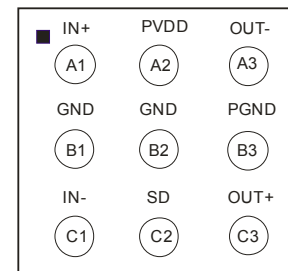

PAM8015

### Applications

- Cellular Phones/Smart Phones
- MP4/MP3
- GPS
- Digital Photo Frame
- Electronic Dictionary
- Portable Game Machines

### Typical Applications Circuit

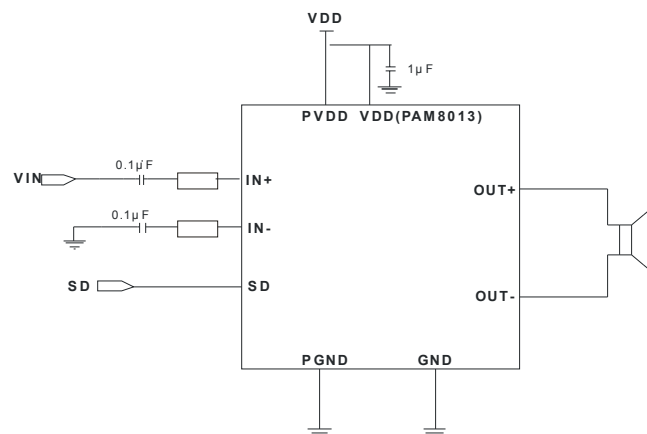

### Pin Descriptions

| Pin Name | PAM8013 | PAM8015 | Function                        |
|----------|---------|---------|---------------------------------|
| IN+      | A1      | A1      | Positive Differential Input     |
| GND      | A2      | B1/B2   | Ground                          |
| OUT-     | A3      | A3      | Negative BTL output             |
| VDD      | B1      | —       | Power Supply                    |
| PVDD     | B2      | A2      | Power Supply                    |
| PGND     | B3      | B3      | Power Ground                    |
| IN-      | C1      | C1      | Negative Differential Input     |
| SD       | C2      | C2      | SD Terminal to Disable the Chip |
| OUT+     | C3      | C3      | Positive BTL Output             |

### Functional Block Diagram

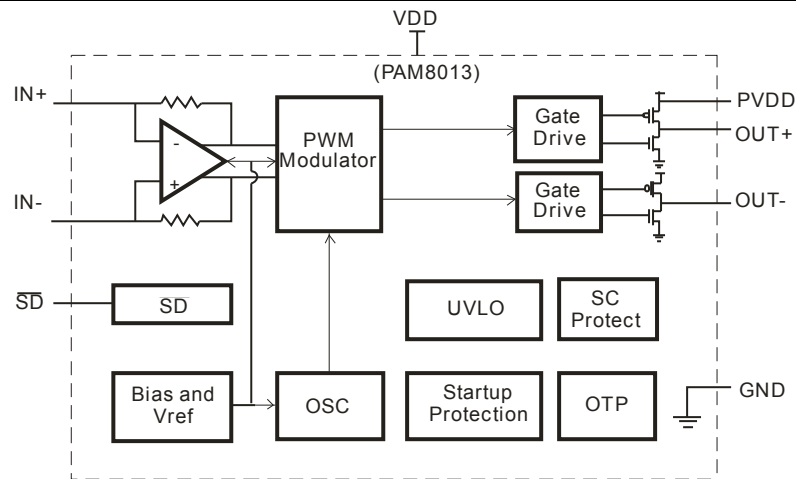

### Absolute Maximum Ratings (@T<sub>A</sub> = +25°C, unless otherwise specified.)

| Parameter                    | Rating                       | Unit |
|------------------------------|------------------------------|------|
| Supply Voltage (VDD)         | 6.0                          | V    |
| Input Voltage(IN+, IN-, SD)  | -0.3 to V <sub>DD</sub> +0.3 | V    |
| Storage Temperature          | -65 to +150                  | °C   |
| Maximum Junction Temperature | 150                          | °C   |

### Recommended Operating Conditions (@T<sub>A</sub> = +25°C, unless otherwise specified.)

| Symbol          | Parameter                           | Min | Max  | Unit |
|-----------------|-------------------------------------|-----|------|------|
| V <sub>DD</sub> | Supply Voltage                      | 2.8 | 5.5  | V    |
| T <sub>A</sub>  | Operating Ambient Temperature Range | -25 | 85   | °C   |
| T <sub>J</sub>  | Junction Temperature                | -40 | +125 | °C   |

**Electrical Characteristics** (@T<sub>A</sub> = +25°C, V<sub>DD</sub> = 5V, Gain = 18dB, R<sub>L</sub> = L(33μH)+R+L(33μH), unless otherwise noted.)

| Symbol            | Parameter                                | Test Conditions   | Min                    | Typ | Max                  | Unit |
|-------------------|--|---|------------------------|-----|----------------------|------|
| VDD               | Supply Voltage                           |   | 2.8                    |     | 5.5                  | V    |
| P <sub>o</sub>    | Output Power                             | THD+N = 10%, f = 1kHz, R = 4Ω                           | V <sub>DD</sub> = 5.0V |     | 3.0                  | W    |
|                   |  |   | V <sub>DD</sub> = 3.6V |     | 1.5                  |      |
|                   |  |   | V <sub>DD</sub> = 3.2V |     | 1.2                  |      |
|                   |  | THD+N = 1%, f = 1kHz, R = 4Ω                            | V <sub>DD</sub> = 5.0V |     | 2.4                  | W    |
|                   |  |   | V <sub>DD</sub> = 3.6V |     | 1.25                 |      |
|                   |  |   | V <sub>DD</sub> = 3.2V |     | 1.0                  |      |
|                   |  | THD+N = 10%, f = 1kHz, R = 8Ω                           | V <sub>DD</sub> = 5.0V |     | 1.75                 | W    |
|                   |  |   | V <sub>DD</sub> = 3.6V |     | 0.90                 |      |
|                   |  |   | V <sub>DD</sub> = 3.2V |     | 0.70                 |      |
|                   |  | THD+N = 1%, f = 1kHz, R = 8Ω                            | V <sub>DD</sub> = 5.0V |     | 1.40                 | W    |
|                   |  |   | V <sub>DD</sub> = 3.6V |     | 0.72                 |      |
|                   |  |   | V <sub>DD</sub> = 3.2V |     | 0.60                 |      |
| THD+N             | Total Harmonic Distortion Plus Noise     | V <sub>DD</sub> = 5.0V, P <sub>o</sub> = 1W, R = 8Ω     | f = 1kHz               |     | 0.17                 | %    |
|                   |  | V <sub>DD</sub> = 3.6V, P <sub>o</sub> = 0.1W, R = 8Ω   |                        |     | 0.16                 |      |
|                   |  | V <sub>DD</sub> = 3.2V, P <sub>o</sub> = 0.1W, R = 8Ω   |                        |     | 0.14                 |      |
|                   |  | V <sub>DD</sub> = 5.0V, P <sub>o</sub> = 0.5W, R = 4Ω   | f = 1kHz               |     | 0.14                 | %    |
|                   |  | V <sub>DD</sub> = 3.6V, P <sub>o</sub> = 0.2W, R = 4Ω   |                        |     | 0.16                 |      |
|                   |  | V <sub>DD</sub> = 3.2V, P <sub>o</sub> = 0.1W, R = 4Ω   |                        |     | 0.17                 |      |
| PSRR              | Power Supply Ripple Rejection            | V <sub>DD</sub> = 3.6V, Inputs ac-grounded with C = 1μF | f = 217Hz              |     | -68                  | dB   |
|                   |  |   | f = 1kHz               |     | -70                  |      |
|                   |  |   | f = 10kHz              |     | -67                  |      |
| Dyn               | Dynamic Range                            | V <sub>DD</sub> = 5V, THD = 1%, R = 8Ω                  | f = 1kHz               |     | 95                   | dB   |
| V <sub>n</sub>    | Output Noise                             | Inputs AC-grounded                                      | No A weighting         |     | 170                  | μV   |
|                   |  |   | A-weighting            |     | 130                  |      |
| η                 | Efficiency                               | RL = 8Ω, THD = 10%                                      | f = 1kHz               |     | 93                   | %    |
|                   |  | RL = 4Ω, THD = 10%                                      |                        |     | 86                   |      |
| I <sub>Q</sub>    | Quiescent Current                        | V <sub>DD</sub> = 5V                                    | No Load                |     | 5                    | mA   |
| I <sub>sd</sub>   | Shutdown Current                         | V <sub>DD</sub> = 2.8V to 5V                            | S <sub>D</sub> = 0V    |     | 1                    | μA   |
| R <sub>dson</sub> | Static Drain-to Source On-state Resistor | High Side PMOS, I = 500mA                               | V <sub>DD</sub> = 5.0V |     | 325                  | mΩ   |
|                   |  | Low Side NMOS, I = 500mA                                | V <sub>DD</sub> = 5.0V |     | 200                  | mΩ   |
| f <sub>sw</sub>   | Switching Frequency                      | V <sub>DD</sub> = 2.8V to 5V                            |                        |     | 400                  | kHz  |
| G <sub>v</sub>    | Closed-loop Gain                         | V <sub>DD</sub> = 2.8V to 5V                            |                        |     | 300K/R <sub>IN</sub> | V/V  |
| R <sub>IN</sub>   | Input Impedance                          | V <sub>DD</sub> = 2.8V to 5V                            |                        |     | 28.5                 | KΩ   |
| V <sub>os</sub>   | Output Offset Voltage                    | Input AC-ground, V <sub>DD</sub> = 5V                   |                        |     | 20                   | mV   |
| VIH               | SD Input High Voltage                    | V <sub>DD</sub> = 5V                                    | 1.4                    |     |                      | V    |
| VIL               | SD Input Low Voltage                     | V <sub>DD</sub> = 5V                                    |                        |     | 1.0                  |      |

**Performance Characteristics** (@ $T_A = +25^\circ\text{C}$ ,  $V_{DD} = 5\text{V}$ , Gain = 18dB,  $R_L = L(33\mu\text{H})+R+L(33\mu\text{H})$ , unless otherwise noted.)

THD+N Vs. Output Power (RL = 4Ω)

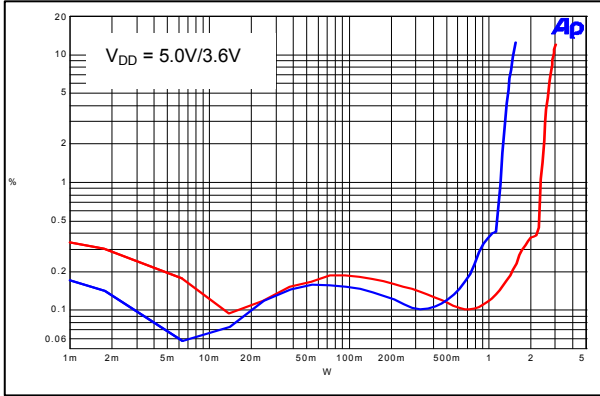

THD+N Vs. Output Power (RL = 8Ω)

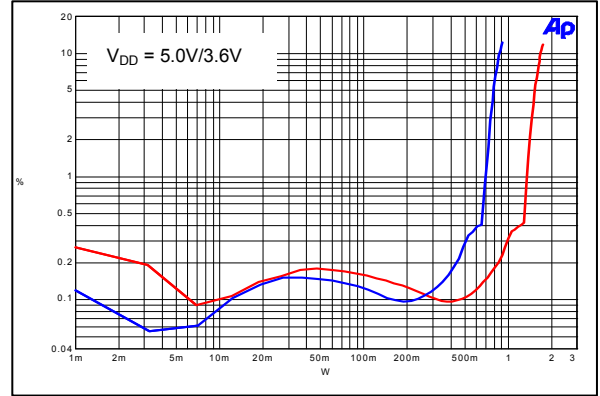

THD+N vs. Frequency

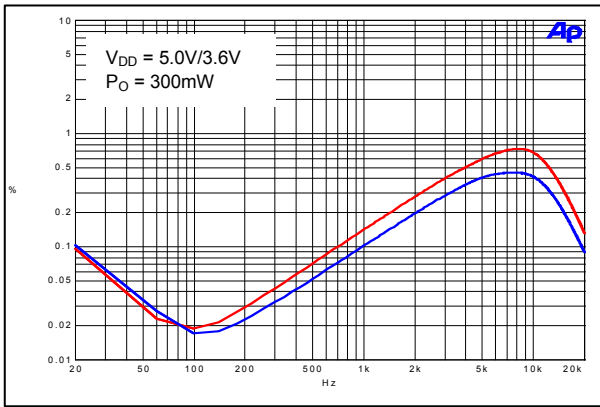

PSRR vs. Frequency

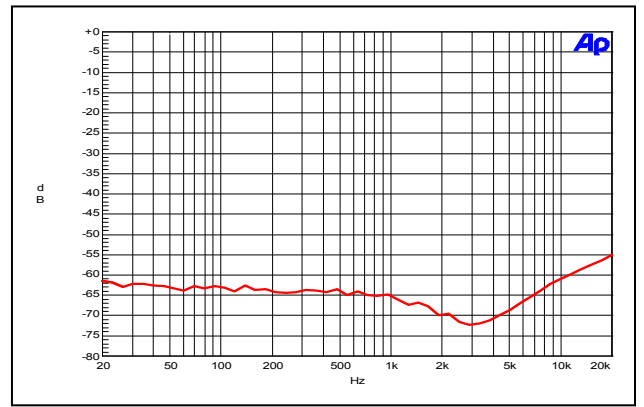

Frequency Response

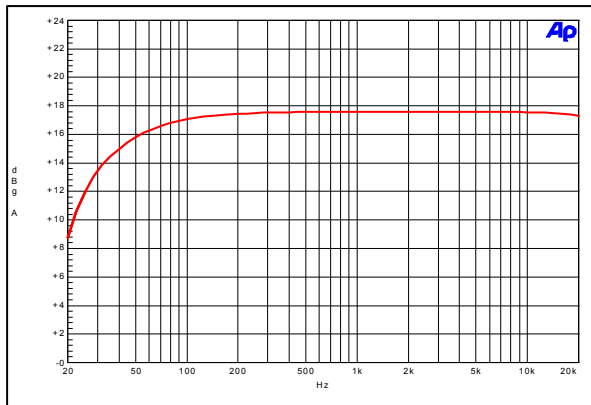

Noise Floor

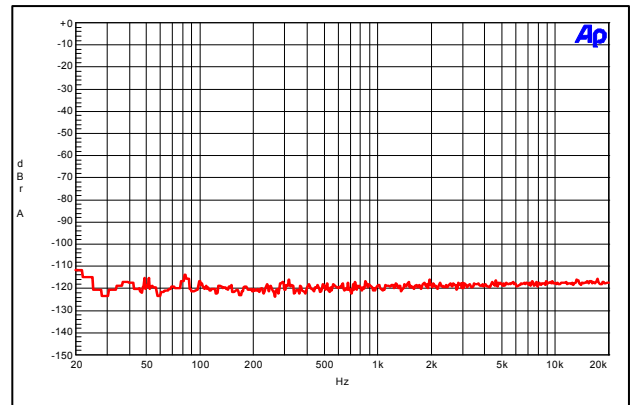

**Performance Characteristics** (cont.) (@ $T_A = +25^\circ\text{C}$ ,  $V_{DD} = 5\text{V}$ , Gain = 18dB,  $R_L = L(33\mu\text{H})+R+L(33\mu\text{H})$ , unless otherwise noted.)

Efficiency vs. Output Power (RL = 4Ω)

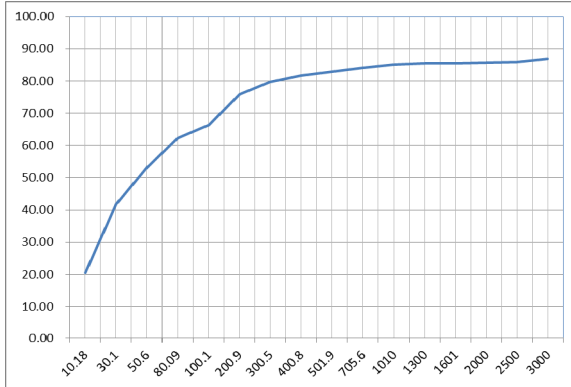

Efficiency vs. Output Power (RL = 8Ω)

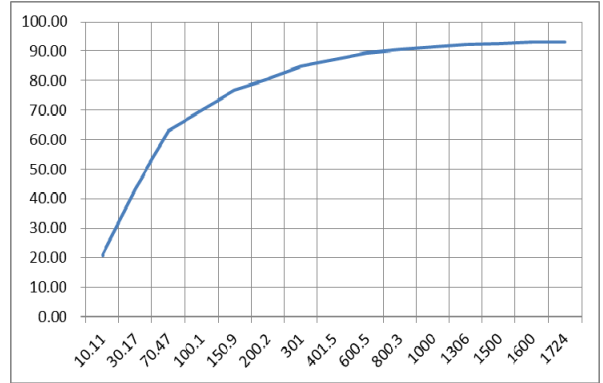

Quiescent Current Vs. Supply Voltage

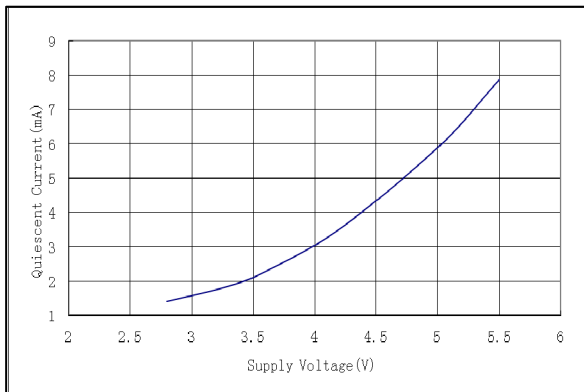

OSC Frequency Vs. Supply Voltage

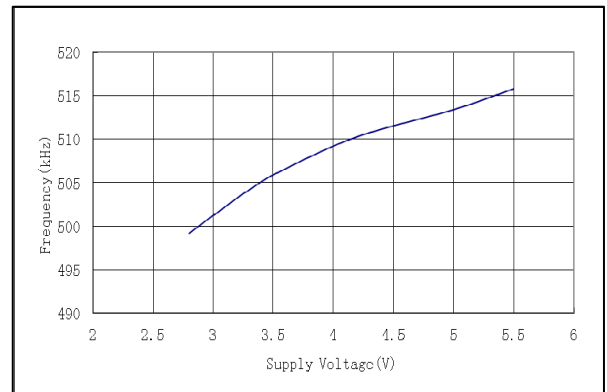

Start-up Response

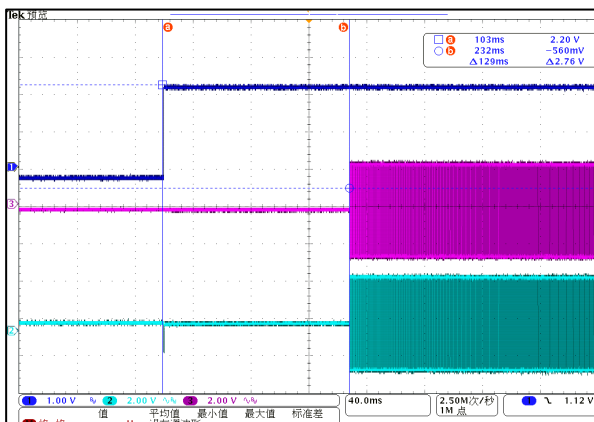

Shutdown Response

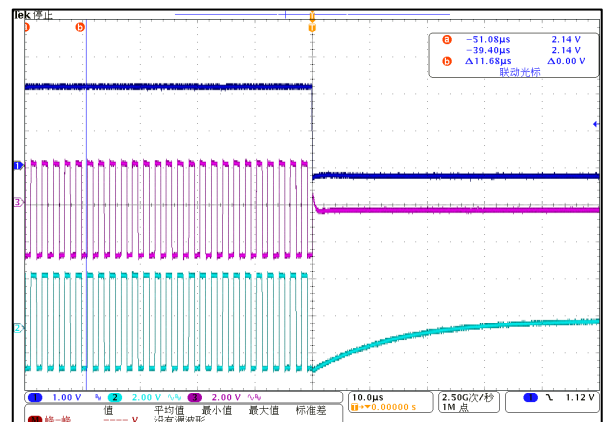

## Application Information

### Input Capacitors (Ci)

In the typical application, an input capacitor,  $C_i$ , is required to allow the amplifier to bias the input signal to the proper DC level for optimum operation. In this case,  $C_i$  and the minimum input impedance  $R_i$  form a high-pass filter with the corner frequency determined in the following equation:

$$f_c = \frac{1}{(2\pi R_i C_i)}$$

It is important to consider the value of  $C_i$  as it directly affects the low frequency performance of the circuit. For example, when  $R_i$  is 150k $\Omega$  and the specification calls for a flat bass response are down to 150Hz. Equation is reconfigured as followed:

$$C_i = \frac{1}{(2\pi R_i f_c)}$$

When input resistance variation is considered, the  $C_i$  is 7nF, so one would likely choose a value of 10nF. A further consideration for this capacitor is the leakage path from the input source through the input network ( $C_i$ ,  $R_i + R_f$ ) to the load. This leakage current creates a DC offset voltage at the input to the amplifier that reduces useful headroom, especially in high gain applications. For this reason, a low-leakage tantalum or ceramic capacitor is the best choice. When polarized capacitors are used, the positive side of the capacitor should face the amplifier input in most applications as the DC level is held at  $V_{DD}/2$ , which is likely higher than the source DC level. Please note that it is important to confirm the capacitor polarity in the application.

### Decoupling Capacitor (CS)

The PAM8013/PAM8015 is a high-performance CMOS audio amplifier that requires adequate power supply decoupling to ensure the output total harmonic distortion (THD) as low as possible. Power supply decoupling also prevents the oscillations causing by long lead length between the amplifier and the speaker.

The optimum decoupling is achieved by using two different types of capacitors that target on different types of noise on the power supply leads. For higher frequency transients, spikes, or digital hash on the line, a good low equivalent-series-resistance (ESR) ceramic capacitor, typically 1 $\mu$ F, is placed as close as possible to the device  $V_{DD}$  pin for the best operation. For filtering lower frequency noise signals, a large ceramic capacitor of 10 $\mu$ F or greater placed near the audio power amplifier is recommended.

### How to Reduce EMI

Most applications require a ferrite bead filter for EMI elimination shown at Figure 1. The ferrite filter reduces EMI around 1MHz and higher. When selecting a ferrite bead, choose one with high impedance at high frequencies, but low impedance at low frequencies.

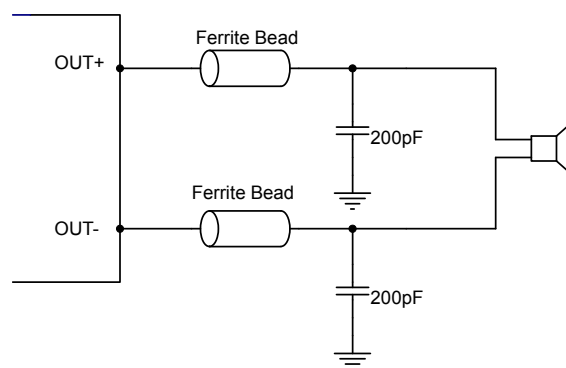

Figure 1 Ferrite Bead Filter to Reduce EMI

## Application Information (cont.)

### Shutdown Operation

In order to reduce power consumption while not in use, the PAM8013/PAM8015 contains shutdown circuitry amplifier off when logic low is placed on the SD pin. By switching the shutdown pin connected to GND, the PAM8013/ PAM8015 supply current draw will be minimized in idle mode.

### Under Voltage Lock-out (UVLO)

The PAM8013/PAM8015 incorporates circuitry designed to detect low supply voltage. When the supply voltage drops to 2.0V or below, the PAM8013/PAM8015 goes into a state of shutdown, and the device comes out of its shutdown state and restore to normal function only when VDD higher than 2.2V.

### Short Circuit Protection (SCP)

The PAM8013/PAM8015 has short circuit protection circuitry on the outputs to prevent the device from damage when output-to-output shorts or output-to-GND shorts occur. When a short circuit occurs, the device immediately goes into shutdown state. Once the short is removed, the device will be reactivated.

### Over Temperature Protection (OTP)

Thermal protection on the PAM8013/PAM8015 prevents the device from damage when the internal die temperature exceeds 150°C. There is a 15°C tolerance on this trip point from device to device. Once the die temperature exceeds the set point, the device will enter the shutdown state and the outputs are disabled. This is not a latched fault. The thermal fault is cleared once the temperature of the die decreased by 40°C. This large hysteresis will prevent motor boating sound well and the device begins normal operation at this point with no external system interaction.

### POP and Click Circuitry

The PAM8013/PAM8015 contains circuitry to minimize turn-on and turn-off transients or “click and pops”, where turn-on refers to either power supply turn-on or device recover from shutdown mode. When the device is turned on, the amplifiers are internally muted. An internal current source ramps up the internal reference voltage. The device will remain in mute mode until the reference voltage reach half supply voltage, 1/2 VDD. As soon as the reference voltage is stable, the device will begin full operation. For the best power-off pop performance, the amplifier should be set in shutdown mode prior to removing the power supply voltage.

## Ordering Information

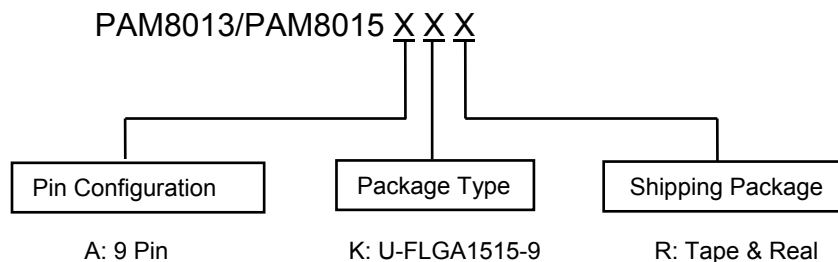

| Part Number | Package      | Standard Package     |
|-------------|--------------|----------------------|
| PAM8013AKR  | U-FLGA1515-9 | 3,000Units/Tape&Real |
| PAM8015AKR  | U-FLGA1515-9 | 3,000Units/Tape&Real |

**Marking Information**

PAM8013- U-FLGA1515-9

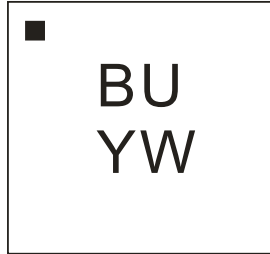

BU: PAM8013 Product Code

Y: Year

W: Week

PAM8015- U-FLGA1515-9

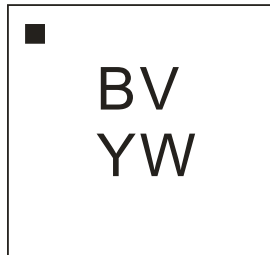

BV: PAM8015 Product Code

Y: Year

W: Week

**Package Outline Dimensions** (All dimensions in mm.)

Please see AP02002 at <http://www.diodes.com/datasheets/ap02002.pdf> for the latest version.

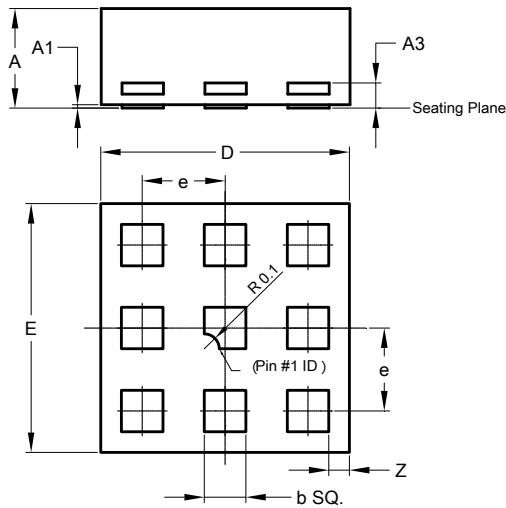

| U-FLGA1515-9         |           |      |      |
|----------------------|-----------|------|------|
| Dim                  | Min       | Max  | Typ  |
| A                    | 0.55      | 0.65 | 0.60 |
| A1                   | 0         | 0.05 | 0.02 |
| A3                   | 0.13 BSC  |      |      |
| b                    | 0.20      | 0.30 | 0.25 |
| D                    | 1.45      | 1.55 | 1.50 |
| E                    | 1.45      | 1.55 | 1.50 |
| e                    | 0.50 BSC  |      |      |
| Z                    | 0.125 BSC |      |      |
| All Dimensions in mm |           |      |      |



## Suggested Pad Layout

Please see AP02001 at <http://www.diodes.com/datasheets/ap02001.pdf> for the latest version.

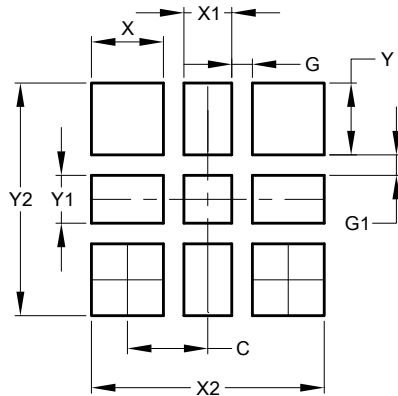

| Dimensions | Value<br>(in mm) |
|------------|------------------|
| C          | 0.587            |
| G          | 0.150            |
| G1         | 0.150            |
| X          | 0.525            |
| X1         | 0.350            |
| X2         | 1.700            |
| Y          | 0.525            |
| Y1         | 0.350            |
| Y2         | 1.700            |

### IMPORTANT NOTICE

DIODES INCORPORATED MAKES NO WARRANTY OF ANY KIND, EXPRESS OR IMPLIED, WITH REGARDS TO THIS DOCUMENT, INCLUDING, BUT NOT LIMITED TO, THE IMPLIED WARRANTIES OF MERCHANTABILITY AND FITNESS FOR A PARTICULAR PURPOSE (AND THEIR EQUIVALENTS UNDER THE LAWS OF ANY JURISDICTION).

Diodes Incorporated and its subsidiaries reserve the right to make modifications, enhancements, improvements, corrections or other changes without further notice to this document and any product described herein. Diodes Incorporated does not assume any liability arising out of the application or use of this document or any product described herein; neither does Diodes Incorporated convey any license under its patent or trademark rights, nor the rights of others. Any Customer or user of this document or products described herein in such applications shall assume all risks of such use and will agree to hold Diodes Incorporated and all the companies whose products are represented on Diodes Incorporated website, harmless against all damages.

Diodes Incorporated does not warrant or accept any liability whatsoever in respect of any products purchased through unauthorized sales channel. Should Customers purchase or use Diodes Incorporated products for any unintended or unauthorized application, Customers shall indemnify and hold Diodes Incorporated and its representatives harmless against all claims, damages, expenses, and attorney fees arising out of, directly or indirectly, any claim of personal injury or death associated with such unintended or unauthorized application.

Products described herein may be covered by one or more United States, international or foreign patents pending. Product names and markings noted herein may also be covered by one or more United States, international or foreign trademarks.

This document is written in English but may be translated into multiple languages for reference. Only the English version of this document is the final and determinative format released by Diodes Incorporated.

### LIFE SUPPORT

Diodes Incorporated products are specifically not authorized for use as critical components in life support devices or systems without the express written approval of the Chief Executive Officer of Diodes Incorporated. As used herein:

A. Life support devices or systems are devices or systems which:

1. are intended to implant into the body, or
2. support or sustain life and whose failure to perform when properly used in accordance with instructions for use provided in the labeling can be reasonably expected to result in significant injury to the user.

B. A critical component is any component in a life support device or system whose failure to perform can be reasonably expected to cause the failure of the life support device or to affect its safety or effectiveness.

Customers represent that they have all necessary expertise in the safety and regulatory ramifications of their life support devices or systems, and acknowledge and agree that they are solely responsible for all legal, regulatory and safety-related requirements concerning their products and any use of Diodes Incorporated products in such safety-critical, life support devices or systems, notwithstanding any devices- or systems-related information or support that may be provided by Diodes Incorporated. Further, Customers must fully indemnify Diodes Incorporated and its representatives against any damages arising out of the use of Diodes Incorporated products in such safety-critical, life support devices or systems.