



CST150P04 P-Ch 40V Fast Switching MOSFETs

- ★ 100% EAS Guaranteed
- ★ Green Device Available
- ★ Super Low Gate Charge
- ★ Excellent CdV/dt effect decline
- ★ Advanced high cell density Trench technology

CST150P04 Product Summary



BVDSS	RDSON	ID
-40V	3.5mΩ	-150A

CST150P04 TO252 Pin Configuration

CST150P04 Description

The CST150P04 is the high cell density trenched P-ch MOSFETs, which provide excellent RDSON and gate charge for most of the synchronous buck converter applications. The CST150P04 meet the RoHS and Green Product requirement, 100% EAS guaranteed with full function reliability approved.

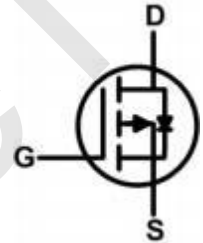

CST150P04 Absolute Maximum Ratings (T_C=25°C unless otherwise noted)

Symbol	Parameter	Limit	Unit
V _{DS}	Drain-Source Voltage (V _{GS} =0V)	-40	V
V _{GS}	Gate-Source Voltage (V _{DS} =0V)	±20	V
I _D	Drain Current-Continuous(T _C =25°C)	-150	A
	Drain Current-Continuous(T _C =100°C)	-104	A
I _{DM (pluse)}	Drain Current-Continuous@ Current-Pulsed (Note 1)	-592	A
P _D	Maximum Power Dissipation(T _C =25°C)	200	W
	Maximum Power Dissipation(T _C =100°C)	100	W
E _{AS}	Avalanche energy (Note 2)	1225	mJ
T _J , T _{STG}	Operating Junction and Storage Temperature Range	-55 To 175	°C

Thermal Characteristic

Symbol	Parameter	Typ	Max	Unit
R _{θJC}	Thermal Resistance, Junction-to-Case		0.95	°C/W



CST150P04 P-Ch 40V Fast Switching MOSFETs

CST150P04 Electrical Characteristics ($T_J=25^\circ\text{C}$ unless otherwise noted)

Symbol	Parameter	Conditions	Min	Typ	Max	Unit
On/Off States						
BV_{DSS}	Drain-Source Breakdown Voltage	$V_{GS}=0V, I_D=-250\mu A$	-40			V
I_{DSS}	Zero Gate Voltage Drain Current	$V_{DS}=-40V, V_{GS}=0V, T_J=25^\circ\text{C}$			-1	μA
		$V_{DS}=-40V, V_{GS}=0V, T_J=125^\circ\text{C}$			-100	μA
I_{GSS}	Gate-Body Leakage Current	$V_{GS}=\pm 20V, V_{DS}=0V$			± 100	nA
$V_{GS(th)}$	Gate Threshold Voltage	$V_{DS}=V_{GS}, I_D=-250\mu A$	-1		-2.5	V
g_{FS}	Forward Transconductance	$V_{DS}=-10V, I_D=-20A$		51		S
$R_{DS(ON)}$	Drain-Source On-State Resistance	$V_{GS}=-10V, I_D=-20A, T_J=25^\circ\text{C}$		3.5	4.5	m Ω
$R_{DS(ON)}$	Drain-Source On-State Resistance	$V_{GS}=-4.5V, I_D=-20A, T_J=25^\circ\text{C}$		4.8	6	m Ω
Dynamic Characteristics						
C_{iss}	Input Capacitance	$V_{DS}=-20V, V_{GS}=0V, f=1.0\text{MHz}$		10733		pF
C_{oss}	Output Capacitance			770		pF
C_{rss}	Reverse Transfer Capacitance			697		pF
R_g	Gate resistance	$V_{GS}=0V, V_{DS}=0V, f=1.0\text{MHz}$		1.7		Ω
Switching Parameters						
$t_{d(on)}$	Turn-on Delay Time	$V_{GS}=-10V, V_{DS}=-20V, R_L=1\Omega, R_{GEN}=3\Omega$		19.6		nS
t_r	Turn-on Rise Time			3.6		nS
$t_{d(off)}$	Turn-Off Delay Time			22.8		nS
t_f	Turn-Off Fall Time			38		nS
Q_g	Total Gate Charge	$V_{GS}=-10V, V_{DS}=-20V, I_D=-20A$		195		nC
Q_{gs}	Gate-Source Charge			24.1		nC
Q_{gd}	Gate-Drain Charge			39.9		nC
Source-Drain Diode Characteristics						
I_{SD}	Source-Drain Current (Body Diode)				-150	A
V_{SD}	Forward on Voltage (Note 3)	$V_{GS}=0V, I_S=-20A$			-1.2	V
t_{rr}	Reverse Recovery Time	$I_F=-20A, dI/dt=-100A/\mu s$		51.1		ns
Q_{rr}	Reverse Recovery Charge	$I_F=-20A, dI/dt=-100A/\mu s$		125.2		nC

Notes 1.Repetitive Rating: Pulse width limited by maximum junction temperature.

Notes 2.EAS condition: $T_J=25^\circ\text{C}, V_{DD}=-40V, V_G=-10V, R_g=25\Omega, L=0.5\text{mH}$.

Notes 3.Repetitive Rating: Pulse width limited by maximum junction temperature.



CST150P04 Typical Electrical And Thermal Characteristics (Curves)

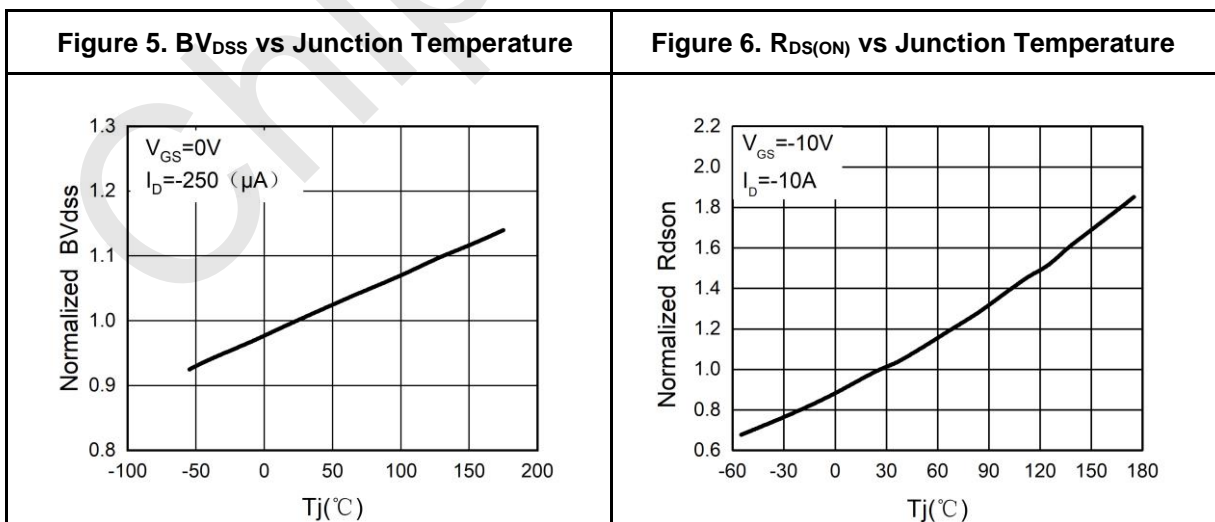
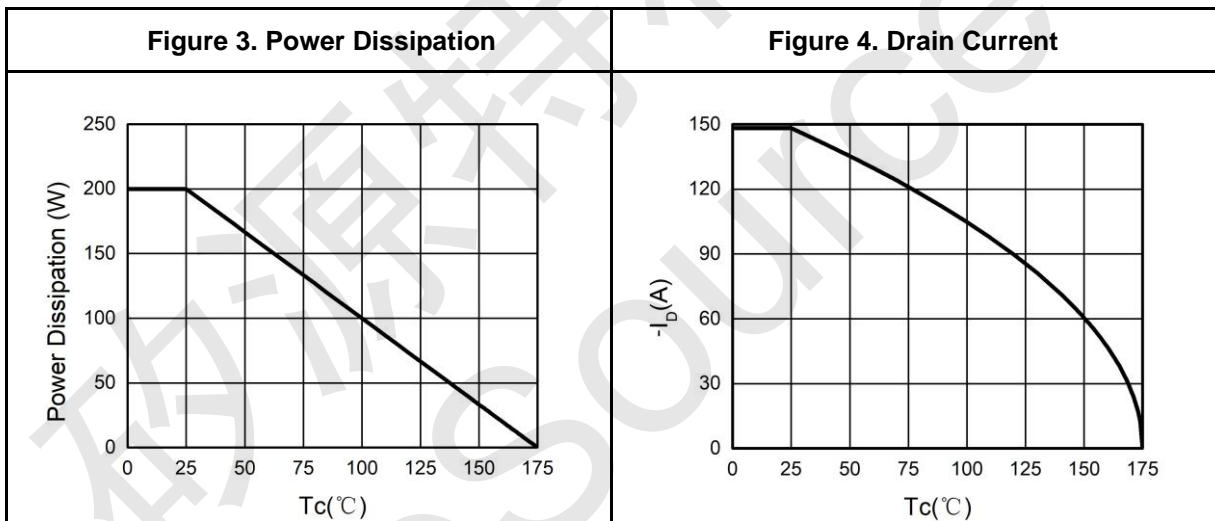
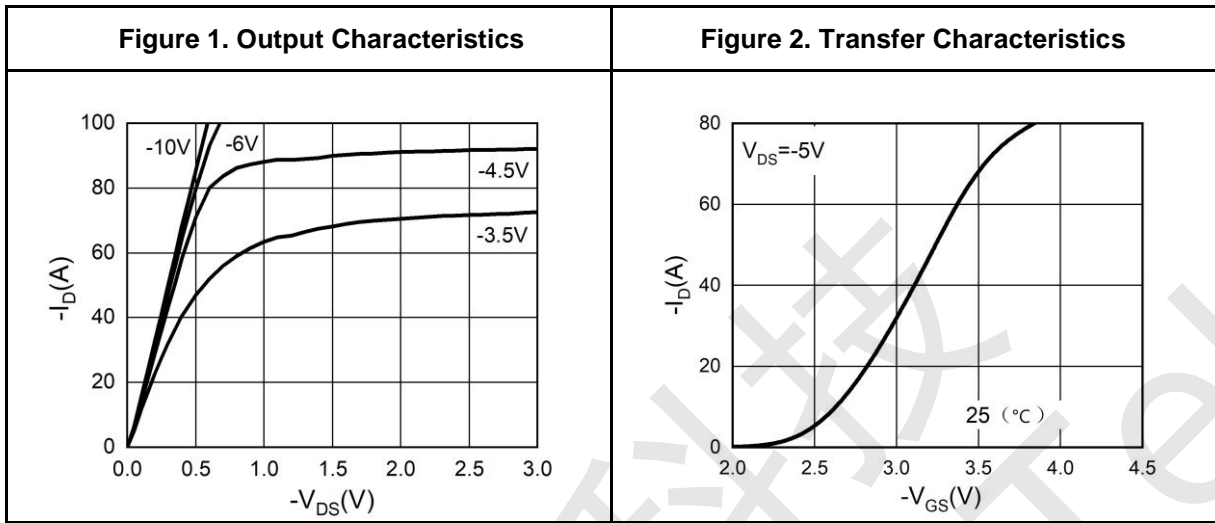



CST150P04 Typical Electrical And Thermal Characteristics (Curves)

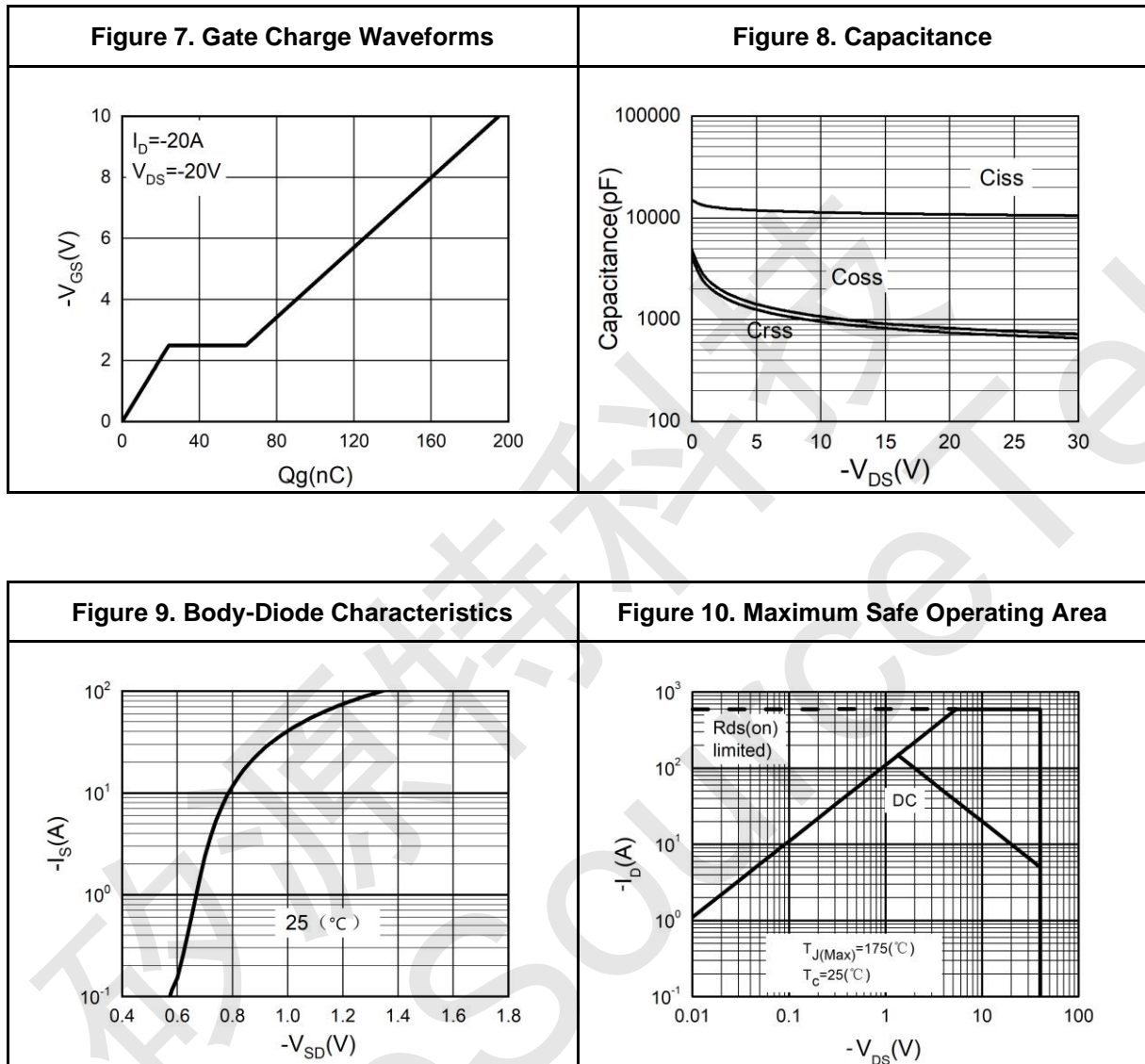



CST150P04 Test Circuit

Gate Charge Test Circuit & Waveform

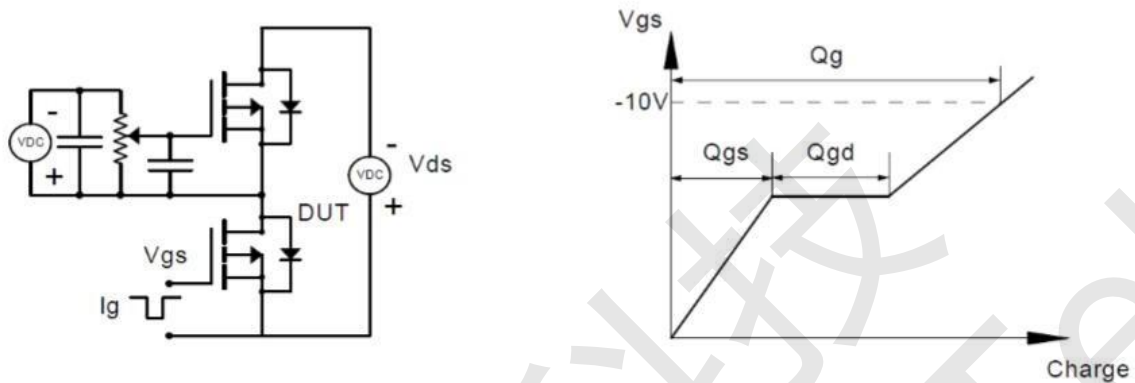

Resistive Switching Test Circuit & Waveforms

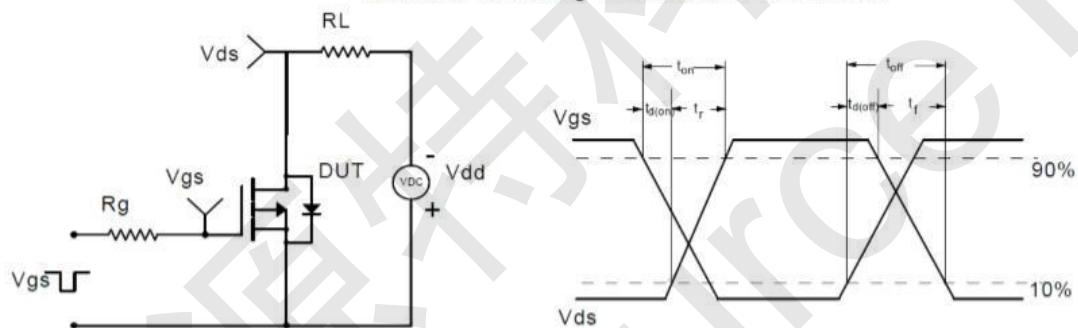

Unclamped Inductive Switching (UIS) Test Circuit & Waveforms

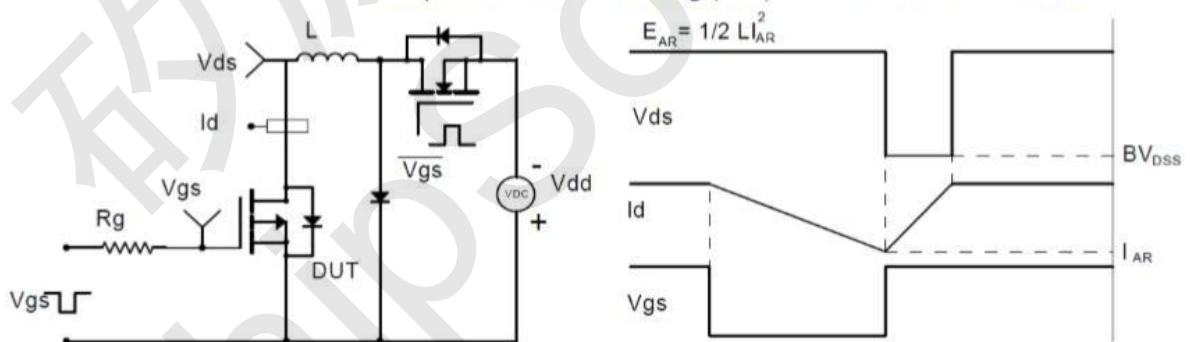

Diode Recovery Test Circuit & Waveforms

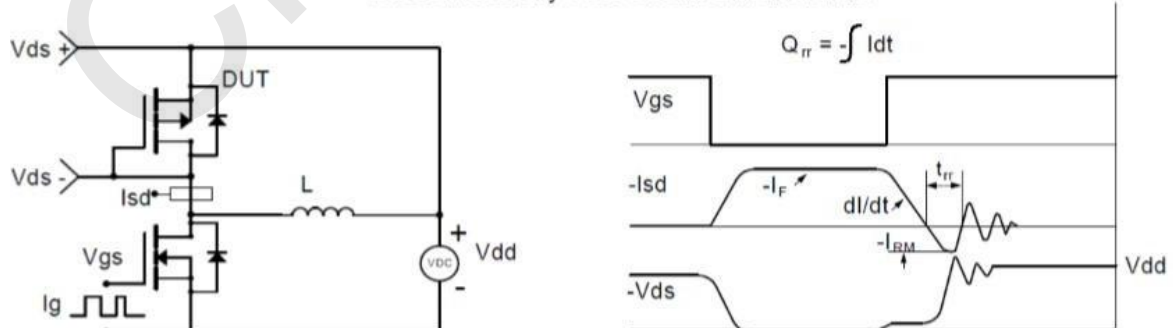



CST150P04 Package Mechanical Data-TO-252

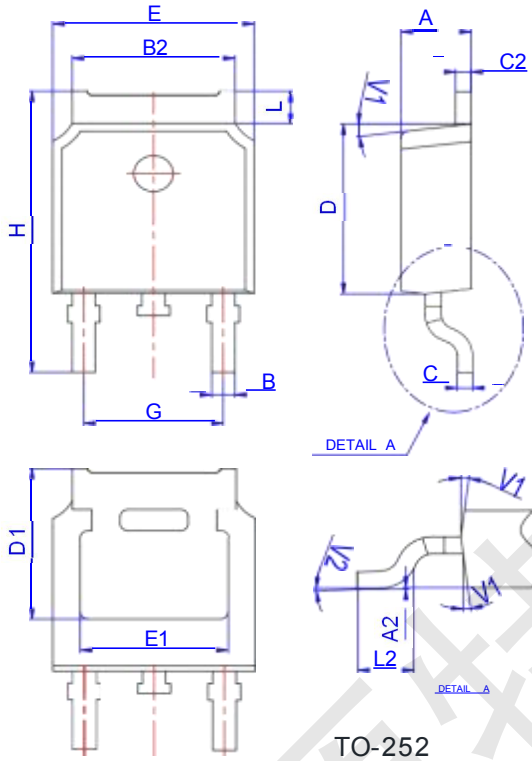

Ref.	Dimensions					
	Millimeters			Inches		
	Min.	Typ.	Max.	Min.	Typ.	Max.
A	2.10		2.50	0.083		0.098
A2	0		0.10	0		0.004
B	0.66		0.86	0.026		0.034
B2	5.18		5.48	0.202		0.216
C	0.40		0.60	0.016		0.024
C2	0.44		0.58	0.017		0.023
D	5.90		6.30	0.232		0.248
D1	5.30REF			0.209REF		
E	6.40		6.80	0.252		0.268
E1	4.63			0.182		
G	4.47		4.67	0.176		0.184
H	9.50		10.70	0.374		0.421
L	1.09		1.21	0.043		0.048
L2	1.35		1.65	0.053		0.065
V1		7°			7°	
V2	0°		6°	0°		6°

CST150P04 Reel Specification-TO-252

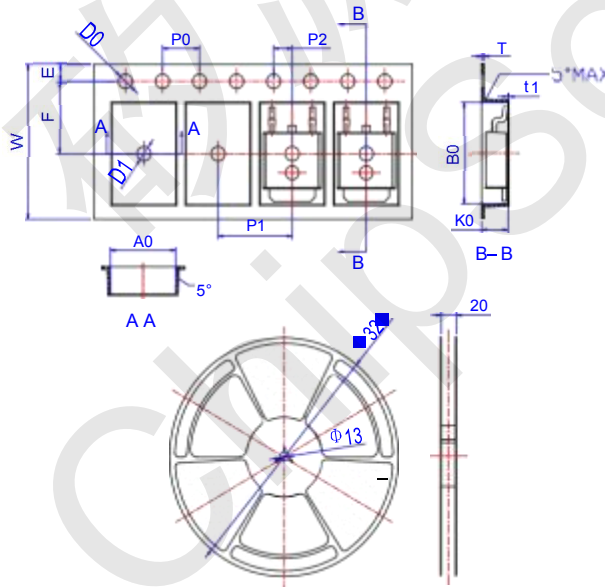

Ref.	Dimensions					
	Millimeters			Inches		
	Min.	Typ.	Max.	Min.	Typ.	Max.
W	15.90	16.00	16.10	0.626	0.630	0.634
E	1.65	1.75	1.85	0.065	0.069	0.073
F	7.40	7.50	7.60	0.291	0.295	0.299
D0	1.40	1.50	1.60	0.055	0.059	0.063
D1	1.40	1.50	1.60	0.055	0.059	0.063
P0	3.90	4.00	4.10	0.154	0.157	0.161
P1	7.90	8.00	8.10	0.311	0.315	0.319
P2	1.90	2.00	2.10	0.075	0.079	0.083
A0	6.85	6.90	7.00	0.270	0.271	0.276
B0	10.45	10.50	10.60	0.411	0.413	0.417
K0	2.68	2.78	2.88	0.105	0.109	0.113
T	0.24		0.27	0.009		0.011
t1	0.10			0.004		
10P0	39.80	40.00	40.20	1.567	1.575	1.583