



1.1 Watt Audio Power Amplifier

BL6281 Features

- Improved PSRR at 217 Hz & 1 KHz 60 dB
- Power output at 5.0V, 1% THD+N, 8Ω 1.1 W (typ.)
- Ultra low shutdown current 0.1 uA (typ.)
- 2.2V – 5.5V operation
- Improved circuitry eliminates pop-click noise during turn-on and turn-off transitions
- No output coupling capacitors, snubber networks or bootstrap capacitors required
- Unity-gain stable
- External gain configuration capability
- Packages: MSOP8、SOP8

BL6281 General Description

The BL6281 is a Class-AB audio power amplifier designed for mobile phone, MID and other portable communication devices. It is capable of delivering 1.1 watts of continuous average power to an 8Ω BTL load with less than 1% distortion (THD+N) from a 5V_{DC} power supply.

The BL6281 was designed specifically to provide high quality output power with a minimal amount of external components. It does not require output coupling capacitors or bootstrap capacitors. And with ultra low shutdown current, the BL6281 is ideally suited for mobile phone, MID and other low voltage applications where minimal power consumption is a primary requirement.

With special pop-click eliminating circuit, the BL6281 provides perfect pop-click characteristic during turn-on and turn-off transitions.

The BL6281 is unity-gain stable and can be configured by external gain-setting resistors.

BL6281 Applications

- MID
- Wireless handsets
- Portable electronic devices
- PDAs, Handheld computers



BL6281 Pin Diagrams

Mini Small Outline Package (MSOP8/SOP8)
(Top View)



MSOP8/SOP8 Marking
(Top View)

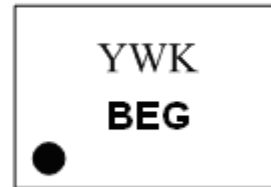

Y - Year Code
WK - Week Code

BL6281 Pin Description

No.	Pin Name	I/O	Description
1	$\overline{\text{SHD}}$	I	Shut-down Logical Control, '0' is active.
2	BP	I/O	Analog ground for inner OPAs. It's about a half of VDD.
3	INP	I	Positive Input
4	INN	I	Negative Input
5	Vout1	O	Negative BTL Output
6	VDD	I/O	Power Supply (2.2 – 5.5 V)
7	GND	I/O	Ground
8	Vout2	O	Positive BTL Output



BL6281 Typical Application Circuit

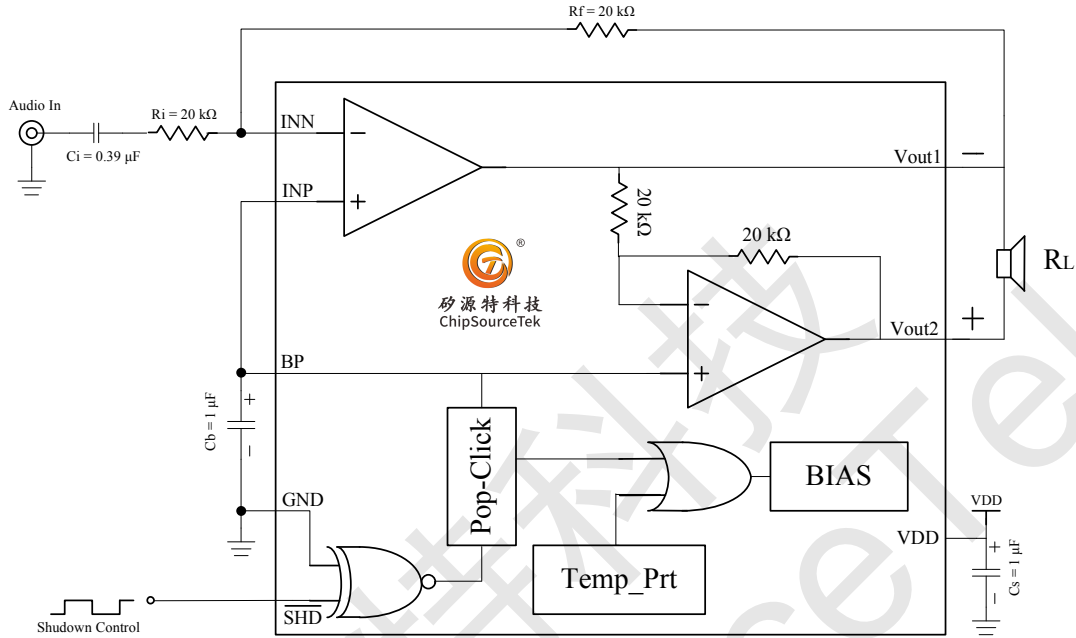

FIGURE 1. BL6281 Typical Application Circuit

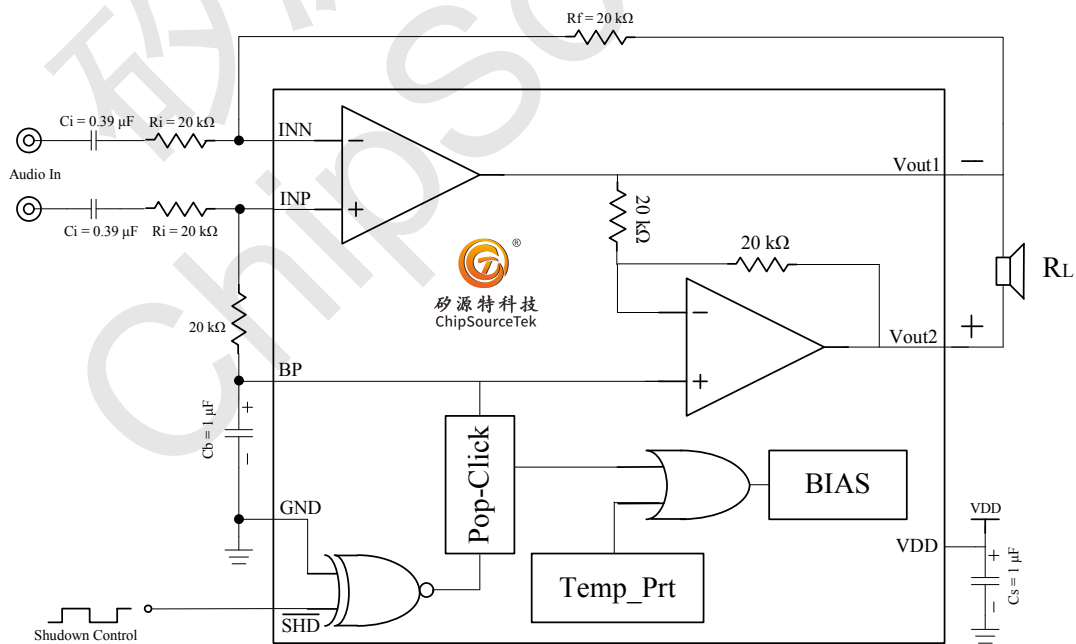

FIGURE 2. BL6281 Differential Amplifier Configuration



BL6281 External Components Description

Components	Functional Description
Ri	Inverting input resistance which sets the closed-loop gain in conjunction with Rf. This resistor also forms a high pass filter with Ci at $f_c = 1/(2\pi R_i * C_i)$.
Ci	Input coupling capacitor which blocks the DC voltage at the amplifiers input terminates. Also creates a high-pass filter with Ri at $f_c = 1/(2\pi R_i * C_i)$.
Rf	Feedback resistance which sets the closed-loop gain in conjunction with Ri. The gain is $A_{VD} = 2 * (R_f / R_i)$.
Cs	Supply bypass capacitor which provides power supply filtering.
Cb	Bypass pin capacitor which provides half-supply filtering. Refer to the section.

BL6281 Absolute Maximum Ratings

Supply Voltage	-0.3V to 6V
Input Voltage	-0.3V to VDD+0.3V
Power Dissipation	

See Dissipation Rating Table

Junction Temperature	-40°C to +150°C
Storage Temperature	-65°C to +150°C
Thermal Resistance	
θ_{JC} (MSOP8)	56°C/W
θ_{JA} (MSOP8)	190°C/W
θ_{JA} (SOP8)	184°C/W

BL6281 Operating Ratings

Temperature Range	-40°C \leq T _A \leq 85°C
Supply Voltage	2.2V \leq V _{DD} \leq 5.5V

NOTE: Absolute Maximum Ratings indicate limits beyond which damage to the device may occur.
Operating Rating indicate conditions for which the device is functional, but do not guarantee specific performance limits.

BL6281 Electrical Characteristics

The following specifications apply for the circuit shown in Figure 1, unless otherwise specified. Limits apply for T_A = 25°C.

□ V_{DD} = 5V

Symbol	Parameter	Conditions	Spec			Units
			Min.	Typ.	Max.	
I _{DD}	Quiescent Power Supply Current	V _{IN} = 0V, 8Ω Load		3.0	8	mA
		V _{IN} = 0V, No Load		2.5	7	mA
I _{SD}	Shutdown Current	V _{IN} =0V, V _{SHD} =GND, No Load		0.1	2	uA



V _{SDIH}	Shutdown Voltage Input High		1.2			V
V _{SDIL}	Shutdown Voltage Input Low				0.9	V
V _{OS}	Output Offset Voltage		-50	6	50	mV
THD+N	Total Harmonic Distortion+Noise	P _o =0.5W _{rms} , f=1KHz,		0.07		%
P _O	Output Power	THD+N<=1%, f=1KHz, 8Ω Load	0.9	1.1		W
PSRR	Power Supply Rejection Ratio	Input terminated with 10Ω, V _{DDRIPPLE} =0.2V _{p-p} , f=217Hz		60		dB
		Input terminated with 10Ω, V _{DDRIPPLE} =0.2V _{p-p} , f=1KHz		61		dB
T _{WU}	Wake-up time			100		ms

□ V_{DD} = 3V

Symbol	Parameter	Conditions	Spec			Units
			Min.	Typ.	Max.	
I _{DD}	Quiescent Power Supply Current	V _{IN} = 0V, 8Ω Load		2	7	mA
		V _{IN} = 0V, No Load		1.5	6	mA
I _{SD}	Shutdown Current	V _{IN} =0V, V _{SHD} =GND, No Load		0.1	2	uA
V _{SDIH}	Shutdown Voltage Input High		1.0			V
V _{SDIL}	Shutdown Voltage Input Low				0.7	V
V _{OS}	Output Offset Voltage		-50	6	50	mV
THD+N	Total Harmonic Distortion+Noise	P _o =0.25W _{rms} , f=1KHz,		0.08		%
P _O	Output Power	THD+N<=1%, f=1KHz, 8Ω Load		310		mW
PSRR	Power Supply Rejection Ratio	Input terminated with 10Ω, V _{DDRIPPLE} =0.2V _{p-p} , f=217Hz		57		dB
		Input terminated with 10Ω, V _{DDRIPPLE} =0.2V _{p-p} , f=1KHz		58		dB
T _{WU}	Wake-up time			75		ms

□ V_{DD} = 2.6V

Symbol	Parameter	Conditions	Spec			Units
			Min.	Typ.	Max.	
I _{DD}	Quiescent Power Supply Current	V _{IN} = 0V, 8Ω Load		1.7		mA
		V _{IN} = 0V, No Load		1.2		mA
I _{SD}	Shutdown Current	V _{IN} =0V, V _{SHD} =GND, No Load		0.1		uA
V _{SDIH}	Shutdown Voltage Input High		1.0			V
V _{SDIL}	Shutdown Voltage Input Low				0.7	V
V _{OS}	Output Offset Voltage		-50	4	50	mV
THD+N	Total Harmonic Distortion+Noise	P _o =0.15W _{rms} , f=1KHz,		0.08		%
P _O	Output Power	THD+N<=1%, f=1KHz, 8Ω Load		230		mW



PSRR	Power Supply Rejection Ratio	Input terminated with 10Ω, V _{DDRIPPLE} =0.2V _{p-p} , f=217Hz	56	dB
		Input terminated with 10Ω, V _{DDRIPPLE} =0.2V _{p-p} , f=1KHz	57	dB
T _{WU}	Wake-up time		70	ms

BL6281 Typical Performance Characteristics

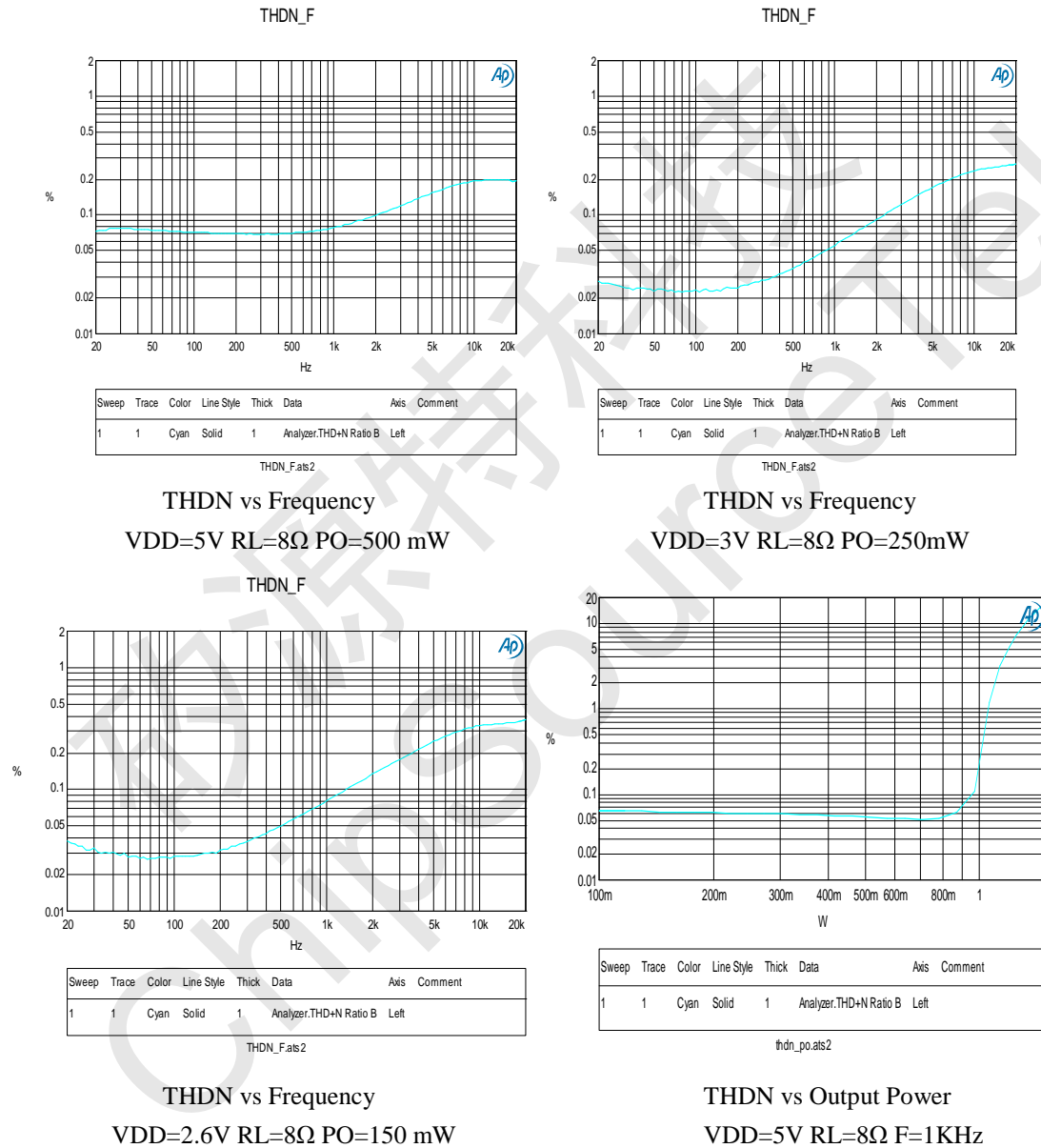

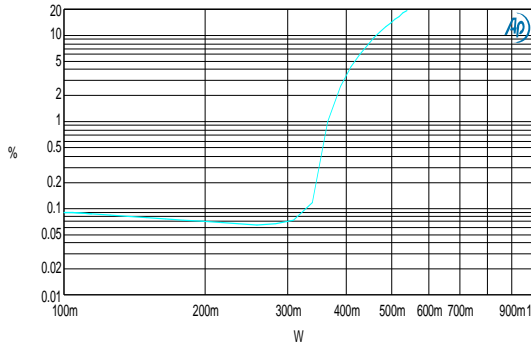

Sweep	Trace	Color	Line Style	Thick	Data	Axis	Comment
1	1	Cyan	Solid	1	Analyzer:THD+N Ratio B	Left	

thdn_po.ats2

THDN vs Output Power
VDD=3V RL=8Ω F=1KHz

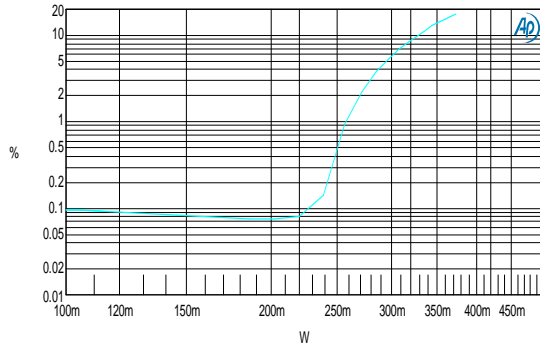

Sweep	Trace	Color	Line Style	Thick	Data	Axis	Comment
1	1	Cyan	Solid	1	Analyzer:THD+N Ratio B	Left	

thdn_po.ats2

THDN vs Output Power
VDD=2.6V RL=8Ω F=1KHz

PSRR_F

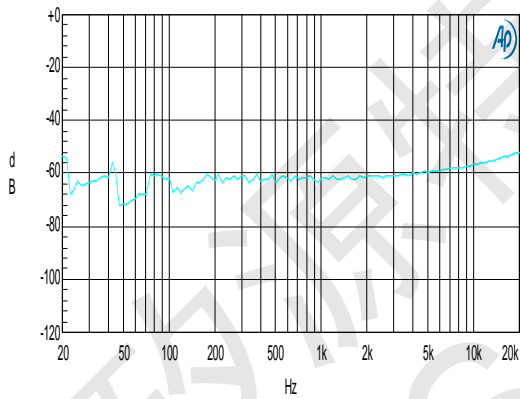

Sweep	Trace	Color	Line Style	Thick	Data	Axis	Comment
1	1	Cyan	Solid	1	Analyzer:Crosstalk B	Left	

psrr_f.ats2

PSRR vs Frequency
VDD=5V RL=8Ω

PSRR_F

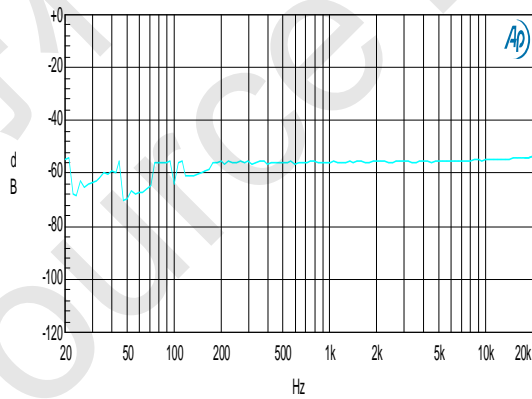

Sweep	Trace	Color	Line Style	Thick	Data	Axis	Comment
1	1	Cyan	Solid	1	Analyzer:Crosstalk B	Left	

psrr_f.ats2

PSRR vs Frequency
VDD=3V RL=8Ω



NOISE_F

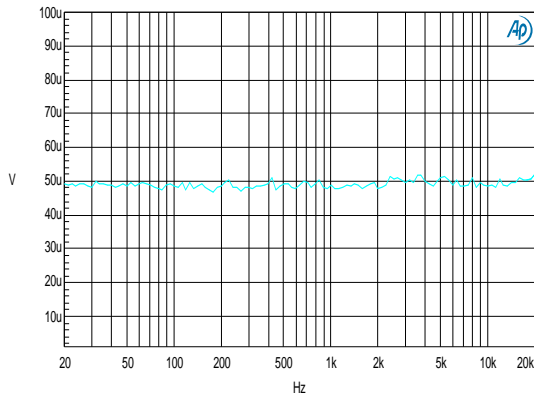

Sweep	Trace	Color	Line Style	Thick	Data	Axis	Comment
1	1	Cyan	Solid	1	Analyzer Amplitude B	Left	

NOISE_F:ats2

Noise Floor 20KBW

VDD=5V RL=8Ω

矽源特科技
ChipSourceTek



BL6281 Package Dimensions

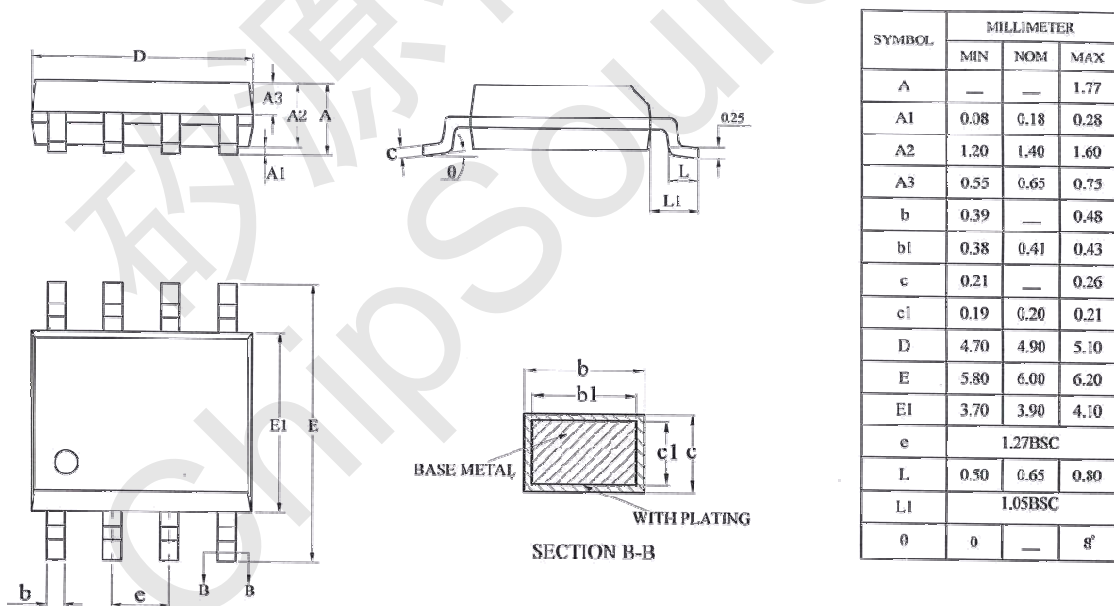
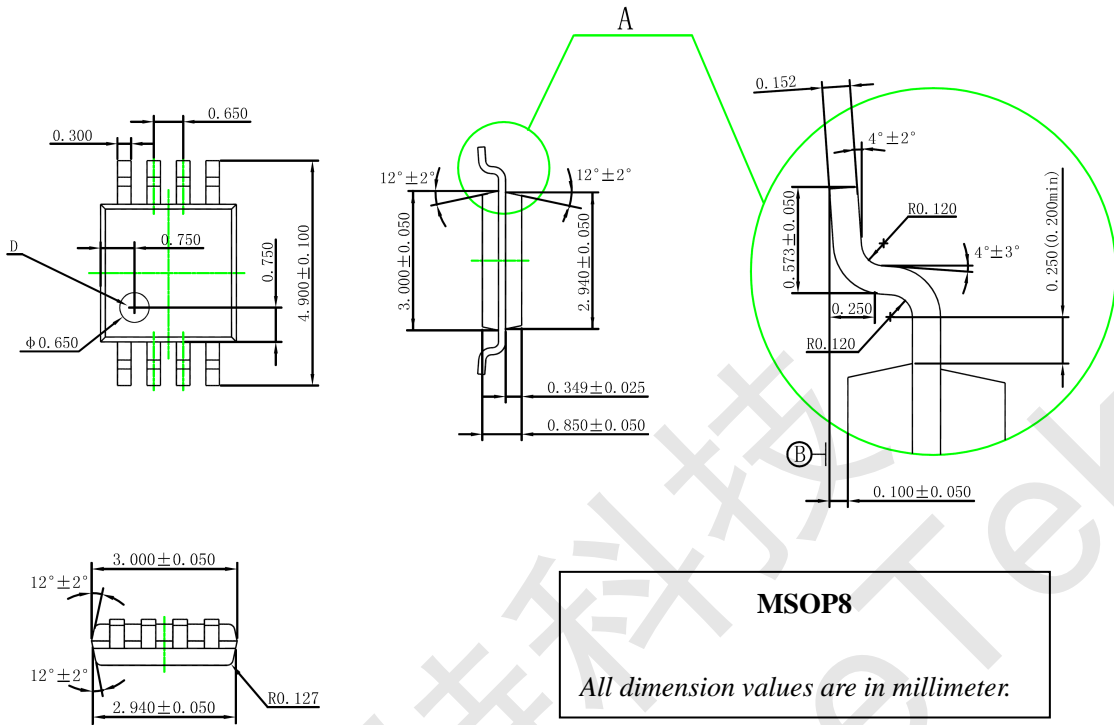

SOP8